



# HP ENVY 15

## Maintenance and Service Guide

Document Part Number: 577090-001

September 2009

This guide is a troubleshooting reference used for maintaining and servicing the computer. It provides comprehensive information on identifying computer features, components, and spare parts; troubleshooting computer problems; and performing computer disassembly procedures.

© Copyright 2009 Hewlett-Packard Development Company, L.P.

ATI and ATI Mobility Radeon are trademarks of Advanced Micro Devices, Inc. Bluetooth is a trademark owned by its proprietor and used by Hewlett-Packard Company under license. Intel and Core are trademarks of Intel Corporation in the U.S. and other countries. Microsoft and Windows are U.S. registered trademarks of Microsoft Corporation. SD Logo is a trademark of its proprietor.

The information contained herein is subject to change without notice. The only warranties for HP products and services are set forth in the express warranty statements accompanying such products and services. Nothing herein should be construed as constituting an additional warranty. HP shall not be liable for technical or editorial errors or omissions contained herein.

First Edition: September 2009

Document Part Number: 577090-001

## Safety warning notice

---



**WARNING:** To reduce the possibility of heat-related injuries or of overheating the computer, do not place the computer directly on your lap or obstruct the computer air vents. Use the computer only on a hard, flat surface. Do not allow another hard surface, such as an adjoining optional printer, or a soft surface, such as pillows or rugs or clothing, to block airflow. Also, do not allow the AC adapter to contact the skin or a soft surface, such as pillows or rugs or clothing, during operation. The computer and the AC adapter comply with the user-accessible surface temperature limits defined by the International Standard for Safety of Information Technology Equipment (IEC 60950).

---

## 1 Product description

## 2 External component identification

Identifying hardware .....	2-1
Top components .....	2-2
Display components .....	2-2
Button .....	2-3
Keys .....	2-4
Lights .....	2-5
TouchPad .....	2-6
TouchPad buttons .....	2-7
Front components .....	2-8
Left-side components .....	2-8
Right-side components .....	2-9
Bottom components .....	2-10

## 3 Illustrated parts catalog

Service tag .....	3-1
Computer major components .....	3-3
Display components .....	3-9
Mass storage devices .....	3-11
Miscellaneous parts .....	3-13
Sequential part number listing .....	3-14

## 4 Removal and replacement procedures

Preliminary replacement requirements .....	4-1
Tools required .....	4-1
Service considerations .....	4-1
Grounding guidelines .....	4-2
Service tag .....	4-5
Component replacement procedures .....	4-6
Computer feet .....	4-6
Battery .....	4-7
Expansion memory module .....	4-8
Top cover .....	4-10
Keyboard .....	4-12
Speaker assembly .....	4-14
Primary memory module .....	4-15
WLAN module .....	4-16
RTC battery .....	4-19
Hard drive .....	4-20

Processor fan/heat sink assembly . . . . .	4-22
Processor . . . . .	4-24
Power button board and cable . . . . .	4-25
Power connector cable . . . . .	4-26
Video fan/heat sink assembly . . . . .	4-27
System board . . . . .	4-29
Display assembly . . . . .	4-33

## 5 Setup Utility (BIOS)

Starting Setup Utility . . . . .	5-1
Using Setup Utility . . . . .	5-1
Changing the language of Setup Utility . . . . .	5-1
Navigating and selecting in Setup Utility . . . . .	5-2
Displaying system information . . . . .	5-2
Restoring default settings in Setup Utility . . . . .	5-2
Exiting Setup Utility . . . . .	5-3
Setup Utility menus . . . . .	5-3
Main menu . . . . .	5-3
Security menu . . . . .	5-3
System Configuration menu . . . . .	5-4
Diagnostics menu . . . . .	5-4
Updating the BIOS . . . . .	5-5
Updating the BIOS . . . . .	5-5

## 6 Specifications

Computer specifications . . . . .	6-1
15.6-in display specifications . . . . .	6-2
Hard drive specifications . . . . .	6-3
9.5-mm, 2.5-in hard drive . . . . .	6-3
8.0-mm, 1.8-in hard drive . . . . .	6-4
Blu-ray ROM DVD±R/RW SuperMulti Double-Layer Drive specifications . . . . .	6-5
DVD±RW and CD-RW SuperMulti Double-Layer Combo Drive specifications . . . . .	6-6
System DMA specifications . . . . .	6-7
System memory map specifications . . . . .	6-7
System interrupt specifications . . . . .	6-8
System I/O address specifications . . . . .	6-9

## 7 Screw listing

Phillips PM2.0×4.0 screw . . . . .	7-1
Phillips PM2.0×12.0 screw . . . . .	7-3
Phillips PM2.0×5.0 screw . . . . .	7-4
Phillips PM2.0×2.0 screw . . . . .	7-5
Phillips PM1.5×1.5 screw . . . . .	7-6
Phillips PM2.0×4.0 broadhead screw . . . . .	7-7
Phillips PM3.0×4.0 screw . . . . .	7-8
Phillips PM2.0×6.0 captive screw . . . . .	7-9
Phillips PM2.0×3.0 screw . . . . .	7-10
Phillips PM2.5×6.0 screw . . . . .	7-13

**8 Backup and recovery**

Creating recovery discs . . . . . 8-2  
 Backing up your information . . . . . 8-3  
     Using Windows Backup and Restore . . . . . 8-4  
     Using system restore points . . . . . 8-4  
 Performing a recovery . . . . . 8-5  
     Recovering from the recovery discs . . . . . 8-6

**9 Connector pin assignments**

Audio-in (microphone). . . . . 9-1  
 Audio-out (headphone) . . . . . 9-1  
 HDMI . . . . . 9-2  
 RJ-45 (network) . . . . . 9-3  
 Universal Serial Bus. . . . . 9-4

**10 Power cord set requirements**

Requirements for all countries and regions . . . . . 10-1  
 Requirements for specific countries and regions . . . . . 10-2

**11 Recycling**

Battery . . . . . 11-1  
 Display . . . . . 11-1

**Index**

---

## Product description

Category	Description
<b>Product name</b>	HP ENVY 15 Notebook PC
<b>Processors</b>	Intel® Core™ i7-820QM 1.73-GHz processor with embedded Northbridge (SC turbo up to 3.06-GHz) Intel Core i7-720QM 1.60-GHz processor with embedded Northbridge (SC turbo up to 2.80-GHz)
<b>Chipset</b>	Intel 5 series express chipsets PM57 platform controller hub (PCH) Peak-M
<b>Graphics</b>	ATI Mobility Radeon™ HD 4830 (M97) Discrete PCI Express Graphics with 1 GB of dedicated video memory (64M×16, 1.5V, 800 MHz, DDR3 @ 1333 MHz)
<b>Panel</b>	15.6-in AntiGlare, full high-definition (FHD) (1920 × 1080), light-emitting diode (LED), dual-channel display assembly 15.6-in BrightView, HD (1368 × 768), LED display assembly 16 × 9 wide aspect ratio Supports privacy filter Includes 2 wireless local-area network (WLAN) antennas Supports ambient light sensor (ALS)
<b>Memory</b>	4 memory module slots (customer accessible/upgradeable), supports up to 16-GB memory Supports DDR3, 1066-MHz dual channel memory

(Continued)

Category	Description
<b>Mass storage devices</b>	Supports either 8.0-mm SATA 1.8-in or 9.5-mm SATA 2.5-in hard drives Supports the following hard drive configurations: 2.5-in, 7200-rpm: ■ 640-GB ■ 500-GB ■ 320-GB ■ 250-GB 1.8-in, 5400-rpm: ■ 320-GB ■ 250-GB ■ 160-GB
<b>Optical drive</b>	External USB support for the following: ■ Blu-ray ROM with LightScribe DVD±R/RW SuperMulti Double-Layer Drive ■ DVD±RW and CD-RW SuperMulti Double-Layer Combo Drive with LightScribe
<b>Microphone</b>	2 integrated digital dual-array microphones Microphone jack
<b>Webcam</b>	Night-vision/low-light VGA camera with infrared LED for illumination Supports OVT7738 camera sensor with F2.0, dual-band lens Fixed (no tilt) Activity light 640 × 480 by 24 frames per second
<b>Audio</b>	HD IDT 92HD75B audio Dolby Home Theater technology 2 stereo speakers with 2-watt power rating Headphone jack
<b>Ethernet</b>	Marvell 88E8072-B1 10/100/1000 Ethernet S3/S5 wake on LAN (AC mode only) Ethernet cable not included

*(Continued)*



Category	Description
<b>Power requirements</b>	120- and 90-W HP Smart Adapter (100–240V) Battery options: <ul style="list-style-type: none"> <li>■ Primary battery: 6-cell, 2.40-Ah (53-Wh) Li-ion battery, user replaceable</li> <li>■ Extended battery: 9-cell, 2.80-Ah (93-Wh) Li-ion battery, user replaceable</li> </ul>
<b>Wireless</b>	Integrated WLAN options by way of wireless module 2 wireless antennas built into display assembly Supports no-WLAN option Support for the following WLAN formats: <ul style="list-style-type: none"> <li>■ Intel WiFi Link 6200 802.11 a/g/n</li> <li>■ Intel WiFi Link 6200 802.11 a/g/n with Bluetooth®</li> <li>■ Intel WiFi Link 5100 802.11 a/g/n</li> <li>■ Intel WiFi Link 5100 802.11 a/g/n with Bluetooth</li> <li>■ Intel WiFi Link 6100 802.11 a/b/g</li> <li>■ Intel WiFi Link 6100 802.11 a/b/g with Bluetooth</li> <li>■ Intel WiFi Link 5100 802.11 a/b/g</li> <li>■ Intel WiFi Link 5100 802.11 a/b/g with Bluetooth</li> <li>■ Intel 1000 802.11 b/g/n</li> <li>■ Intel 1000 802.11 b/g/n with Bluetooth</li> <li>■ Intel 1000 802.11 b/g</li> <li>■ Intel 1000 802.11 b/g with Bluetooth</li> </ul>
<b>External media cards</b>	Digital Media Slot Supports the following digital card formats: <ul style="list-style-type: none"> <li>■ MultiMediaCard</li> <li>■ micro MultiMediaCard (adapter required)</li> <li>■ MultiMediaCard Plus</li> <li>■ Secure Digital (SD) Memory Card</li> <li>■ micro Secure Digital Memory Card (adapter required)</li> <li>■ Secure Digital High Capacity Memory Card</li> </ul>

*(Continued)*

Category	Description
<b>Ports</b>	<p>3.5-mm headphone/microphone combo jack (stereo, supports jack detection)</p> <p>eSATA/USB 2.0 combo port (1)</p> <p>High Definition Multimedia Interface (HDMI) v1.3b supporting 1920 × 1080 at 60 Hz</p> <p>HP Smart Adapter AC adapter plug</p> <p>RJ-45</p> <p>Primary battery connector</p> <p>Secondary battery connector</p> <p>USB 3.0 ports (2, each capable of driving an external optical drive)</p> <p>USB 2.0 ports (2, each capable of driving an external optical drive)</p> <p> The total combined power for all USB ports is 3.0 amps, with all power available from any single port. This power is available whenever the AC adapter is supplying power, including S3 and S5 modes.</p>
<b>Keyboard/ pointing devices</b>	<p>Full-size optimized keyboard with 1.8-mm keystroke travel distance</p> <p>TouchPad with gesture support (media “M,” scroll, pinch, zoom)</p> <p>Taps enabled by default</p>
<b>Serviceability</b>	<p><b>End-user replaceable parts:</b></p> <p>AC adapter</p> <p>Battery</p> <p>External optical drive</p> <p>Memory (only 2 slots are customer accessible)</p>
<b>Security</b>	<p>Security cable slot with adapter</p>
<b>Operating system</b>	<p><b>Preinstalled:</b></p> <ul style="list-style-type: none"> <li>■ Microsoft® Windows® 7 Home Premium 64</li> <li>■ Microsoft Windows 7 Professional 64</li> <li>■ Configurable Linux embedded</li> </ul>

---

## External component identification

### Identifying hardware

Components included with the computer may vary by region and model. The illustrations in this chapter identify the standard features on most computer models.

To see a list of hardware installed in the computer:

» Select **Start > Control Panel > System and Security**. Then in the System area, click **Device Manager**.

You can also add hardware or modify device configurations using Device Manager.





Windows includes the User Account Control feature to improve the security of your computer. You may be prompted for your permission or password for tasks such as installing software, running utilities, or changing Windows settings. Refer to Help and Support for more information.

---

## Top components

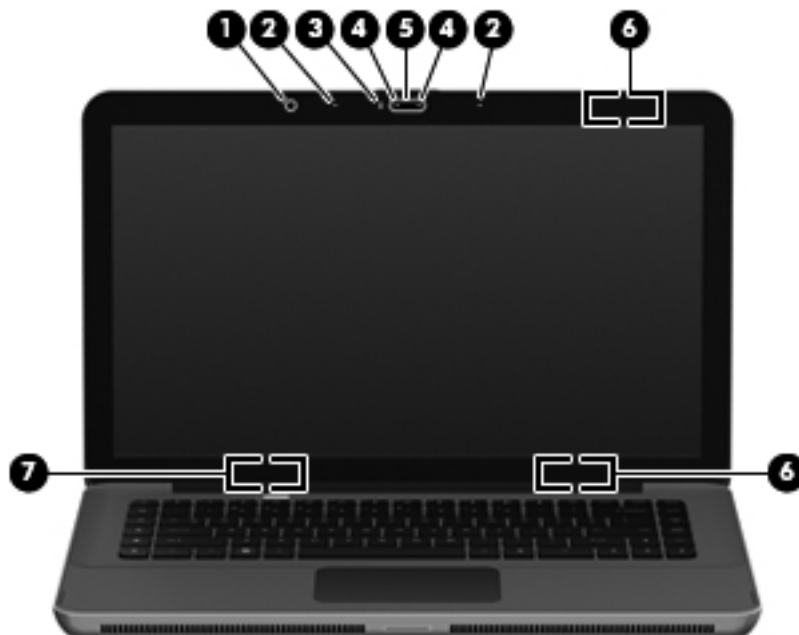
### Display components



Item	Component	Description
(1)	Ambient light sensor	Adjusts the screen brightness levels automatically, based on surrounding lighting conditions.
(2)	Internal microphones (2)	Record sound.
(3)	Webcam light	On: The webcam is in use.
(4)	Webcam infrared (IR) lights (2)	Improve the webcam picture quality in low-light conditions.
(5)	Webcam	Records video and captures still photographs.
(6)	Wireless antennas (2)	Send and receive signals from one or more wireless devices. These antennas are not visible from the outside of the computer. <p> For optimal transmission, keep the areas immediately around the antennas free from obstructions.</p> <p>To see wireless regulatory notices, refer to the section of the <i>Regulatory, Safety and Environmental Notices</i> that applies to your country or region. These notices are located in Help and Support.</p>
(7)	Internal display switch	Turns off the display and initiates Sleep if the display is closed while the power is on. <p> The internal display switch is not visible from the outside of the computer.</p>



## Button

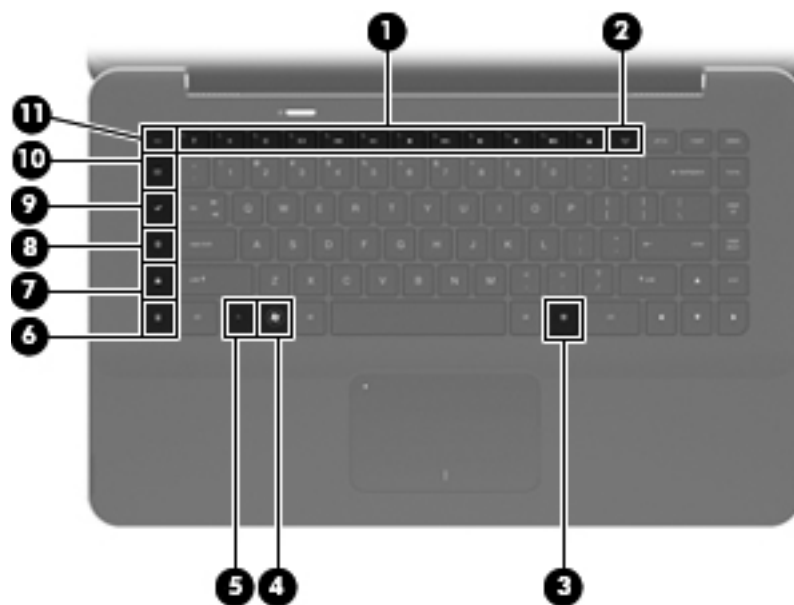

Component	Description
Power button	<ul style="list-style-type: none"> <li>■ When the computer is off, press the button to turn on the computer.</li> <li>■ When the computer is on, press the button briefly to initiate Sleep.</li> <li>■ When the computer is in the Sleep state, press the button briefly to exit Sleep.</li> <li>■ When the computer is in Hibernation, press the button briefly to exit Hibernation.</li> </ul> <p>If the computer has stopped responding and Windows shutdown procedures are ineffective, press and hold the power button for at least 5 seconds to turn off the computer.</p> <p>To learn more about your power settings, select <b>Start &gt; Control Panel &gt; System and Security &gt; Power Options</b>.</p>

## Keys



Item	Component	Description
(1)	Action keys	Execute frequently used system functions.
(2)	<b>wireless</b> key	Turns the wireless feature on or off.  This key does not establish a wireless connection. To establish a wireless connection, a wireless network must also be set up.
(3)	Windows applications key	Displays a shortcut menu for items beneath the cursor.
(4)	Windows logo key	Displays the Windows Start menu.
(5)	<b>fn</b> key	Executes frequently used system functions when pressed in combination with a function key or the <b>esc</b> key.
(6)	<b>calculator</b> key	Opens the Windows calculator function.
(7)	<b>print options</b> key	Opens the Print Options window of the active Windows program.
(8)	<b>Web</b> key	Opens a Web browser.  Until you have set up your Internet or network services, the <b>Web</b> key opens the Windows Internet Connection Wizard. After you have set up your Internet or network services and your Web browser home page, you can press the <b>Web</b> key to quickly access your home page and the Internet.
(9)	<b>Media Launch</b> key	Opens HP MediaSmart. HP MediaSmart turns your computer into a mobile entertainment center. You can enjoy music and movies and manage and edit your photo collections.
(10)	<b>mail</b> key	Opens your default e-mail program.  The first time you press the <b>mail</b> key, you may be prompted to set up your e-mail account. After you have set up your e-mail, you can press the <b>mail</b> key to quickly access your e-mail.
(11)	<b>esc</b> key	Displays system information when pressed in combination with the <b>fn</b> key.

## Lights

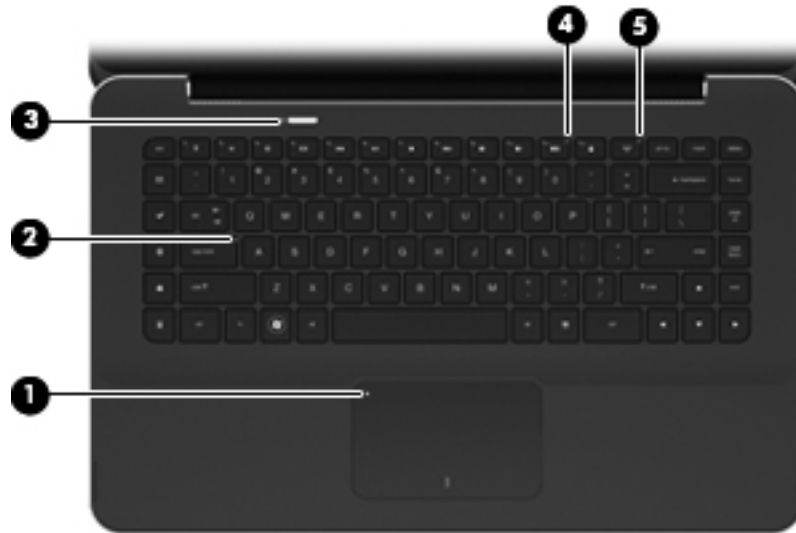

Item	Component	Description
(1)	TouchPad light	<ul style="list-style-type: none"> <li>■ Amber: The TouchPad is off.</li> <li>■ Off: The TouchPad is on.</li> </ul>
(2)	Caps lock light	White: Caps lock is on.
(3)	Power light	<ul style="list-style-type: none"> <li>■ White: The computer is on.</li> <li>■ Blinking white: The computer is in the Sleep state.</li> <li>■ Off: The computer is off or in Hibernation.</li> </ul>
(4)	Mute light	Amber: Computer sound is off.
(5)	Wireless light	<ul style="list-style-type: none"> <li>■ Off: An integrated wireless device, such as a WLAN device and/or a Bluetooth device, is on.</li> <li> Wireless devices are enabled at the factory.</li> <li>■ Amber: All wireless devices are off.</li> </ul>

## TouchPad

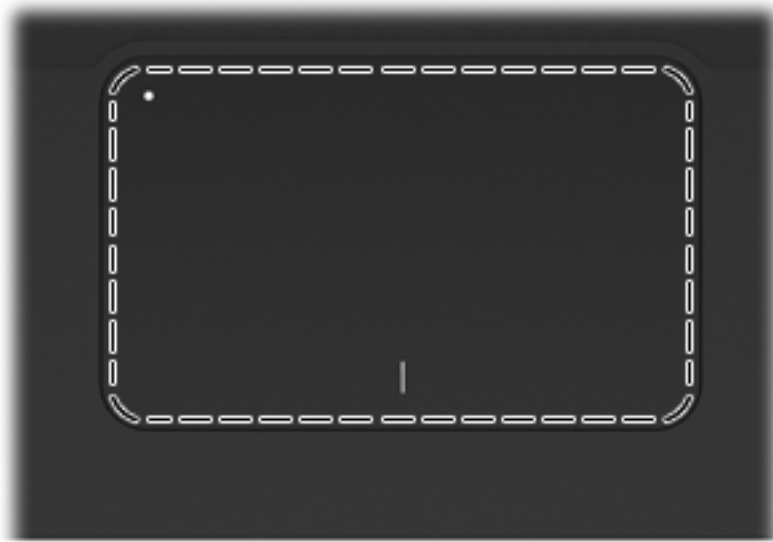

Component	Description
TouchPad*	Moves the pointer and selects or activates items on the screen.

\*This table describes factory settings. To view and change pointing device preferences, select **Start > Devices and Printers**. Then, right-click the device representing your computer, and select **Mouse settings**.



## TouchPad buttons

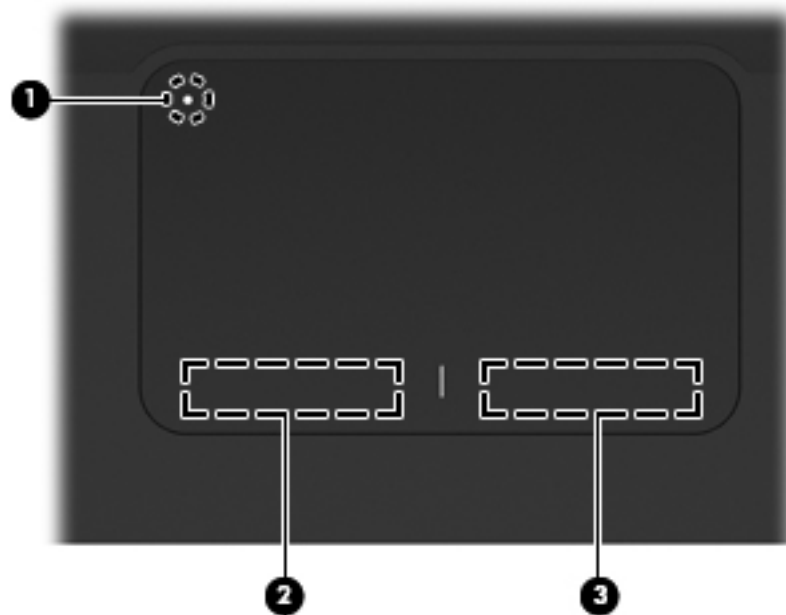

Item	Component	Description
(1)	TouchPad on/off button	Turns the TouchPad on and off. Lightly press the button and hold for 2 seconds to turn the TouchPad on and off.
(2)	Left TouchPad button*	Functions like the left button on an external mouse.
(3)	Right TouchPad button*	Functions like the right button on an external mouse.

\*This table describes factory settings. To view and change pointing device preferences, select **Start > Devices and Printers**. Then, right-click the device representing your computer, and select **Mouse settings**.

## Front components

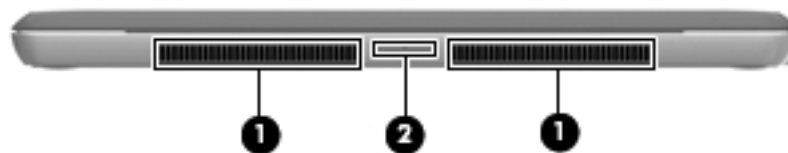

Item	Component	Description
(1)	Vents (2)	Enable airflow to cool internal components.  The computer fan starts up automatically to cool internal components and prevent overheating. It is normal for the internal fan to cycle on and off during routine operation.
(2)	Digital Media Slot	Supports the following digital card formats: <ul style="list-style-type: none"> <li>■ MultiMediaCard</li> <li>■ micro MultiMediaCard (adapter required)</li> <li>■ MultiMediaCard Plus</li> <li>■ Secure Digital Memory Card</li> <li>■ micro Secure Digital Memory Card (adapter required)</li> <li>■ Secure Digital High Capacity Memory Card</li> </ul>



## Left-side components



Item	Component	Description
(1)	Battery light	<ul style="list-style-type: none"> <li>■ Off: The computer is running on battery power.</li> <li>■ Blinking amber: The battery has reached a low battery level, a critical battery level, or there is a battery error.</li> <li>■ Amber: A battery is charging.</li> <li>■ White: The computer is connected to external power and the battery is fully charged.</li> </ul>
(2)	Power connector	Connects an AC adapter.
(3)	Vent	Enables airflow to cool internal components.  The computer fan starts up automatically to cool internal components and prevent overheating. It is normal for the internal fan to cycle on and off during routine operation.
(4)	Drive light	<ul style="list-style-type: none"> <li>■ Blinking white: The hard drive is being accessed.</li> <li>■ Amber (select models only): HP ProtectSmart Hard Drive Protection has temporarily parked the hard drive.</li> </ul>
(5)	Speaker	Produces sound.

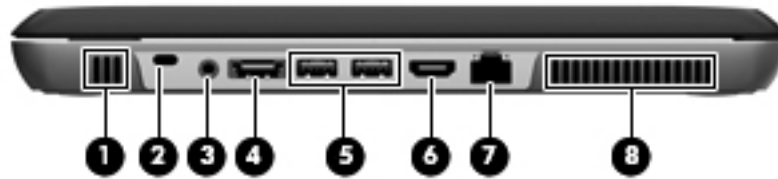

## Right-side components

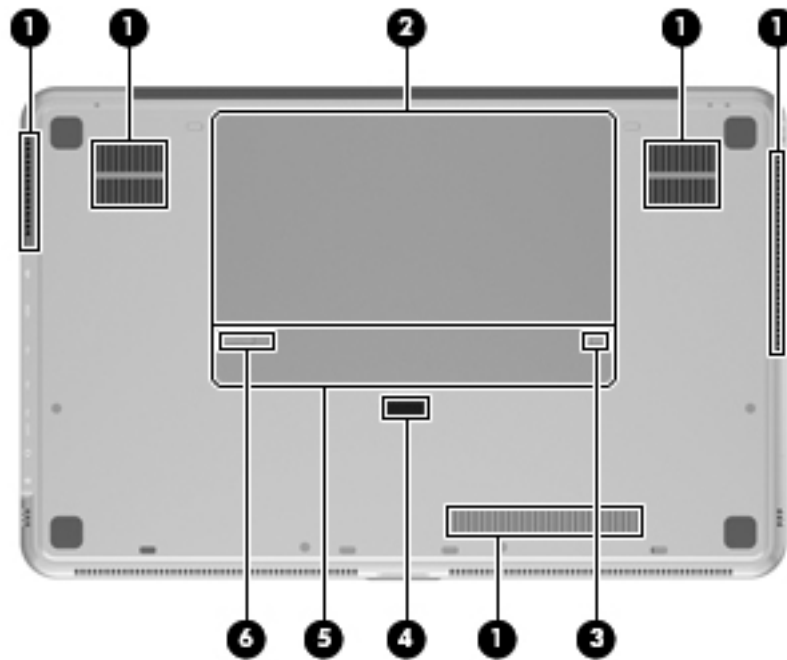

Item	Component	Description
(1)	Speaker	Produces sound.
(2)	Security cable slot	Attaches an optional security cable to the computer.  The security cable is designed to act as a deterrent, but it may not prevent the computer from being mishandled or stolen.
(3)	Audio-out (headphone) jack/Audio-in (microphone) jack	Produces sound when connected to optional powered stereo speakers, headphones, earbuds, a headset, or television audio. Also connects an optional headset microphone.  When a device is connected to the jack, the device speakers are disabled.
(4)	eSATA/USB port	Connects a high-performance eSATA component, such as an eSATA external hard drive, or connects an optional USB device.
(5)	USB ports (2)	Connect optional USB devices.
(6)	HDMI port	Connects an optional video or audio device, such as a high-definition television, or any compatible digital or audio component.
(7)	RJ-45 (network) jack	Connects a network cable.
(8)	Vent	Enables airflow to cool internal components.  The computer fan starts up automatically to cool internal components and prevent overheating. It is normal for the internal fan to cycle on and off during routine operation.

## Bottom components



Item	Component	Description
(1)	Vents (5)	Enable airflow to cool internal components.  The computer fan starts up automatically to cool internal components and prevent overheating. It is normal for the internal fan to cycle on and off during routine operation.
(2)	Battery bay	Holds the primary battery.  The primary battery is preinstalled in the battery bay at the factory.
(3)	Battery lock	Locks the primary battery inside the battery bay.
(4)	Accessory battery connector	Connects an optional accessory battery.
(5)	Memory module compartment	Holds the memory modules.
(6)	Battery release latch	Releases the primary battery from the battery bay.

## Illustrated parts catalog

### Service tag

When ordering parts or requesting information, provide the computer serial number and model number provided on the service tag.



The battery must be removed to gain access to the service tag. See the “Battery” section in Chapter 4 (“Removal and replacement procedures”) for battery removal and replacement instructions.

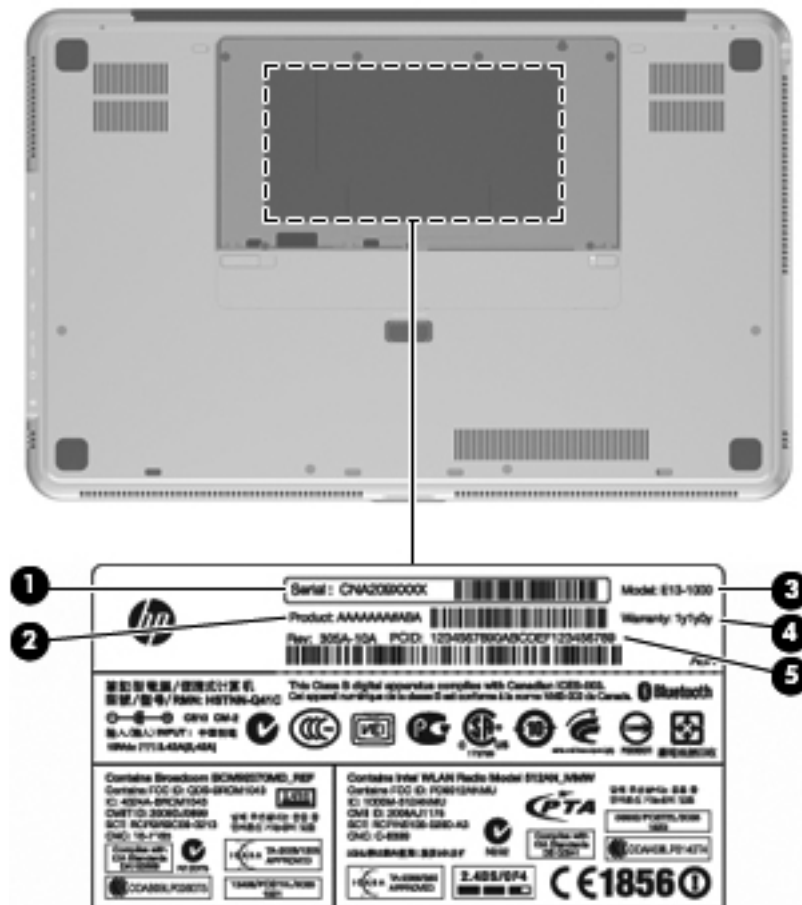

<b>Item</b>	<b>Component</b>	<b>Description</b>
(1)	Serial number (s/n)	This is an alphanumeric identifier that is unique to each product.
(2)	Product name	This is the product name affixed to the front of the computer.
(3)	Model description	This is the alphanumeric identifier used to locate documents, drivers, and support for the computer.
(4)	Warranty period	This number describes the duration (in years) of the warranty period for the computer.
(5)	Part number/Product number (p/n)	This number provides specific information about the product's hardware components. The part number helps a service technician determine what components and parts are needed.

## Computer major components

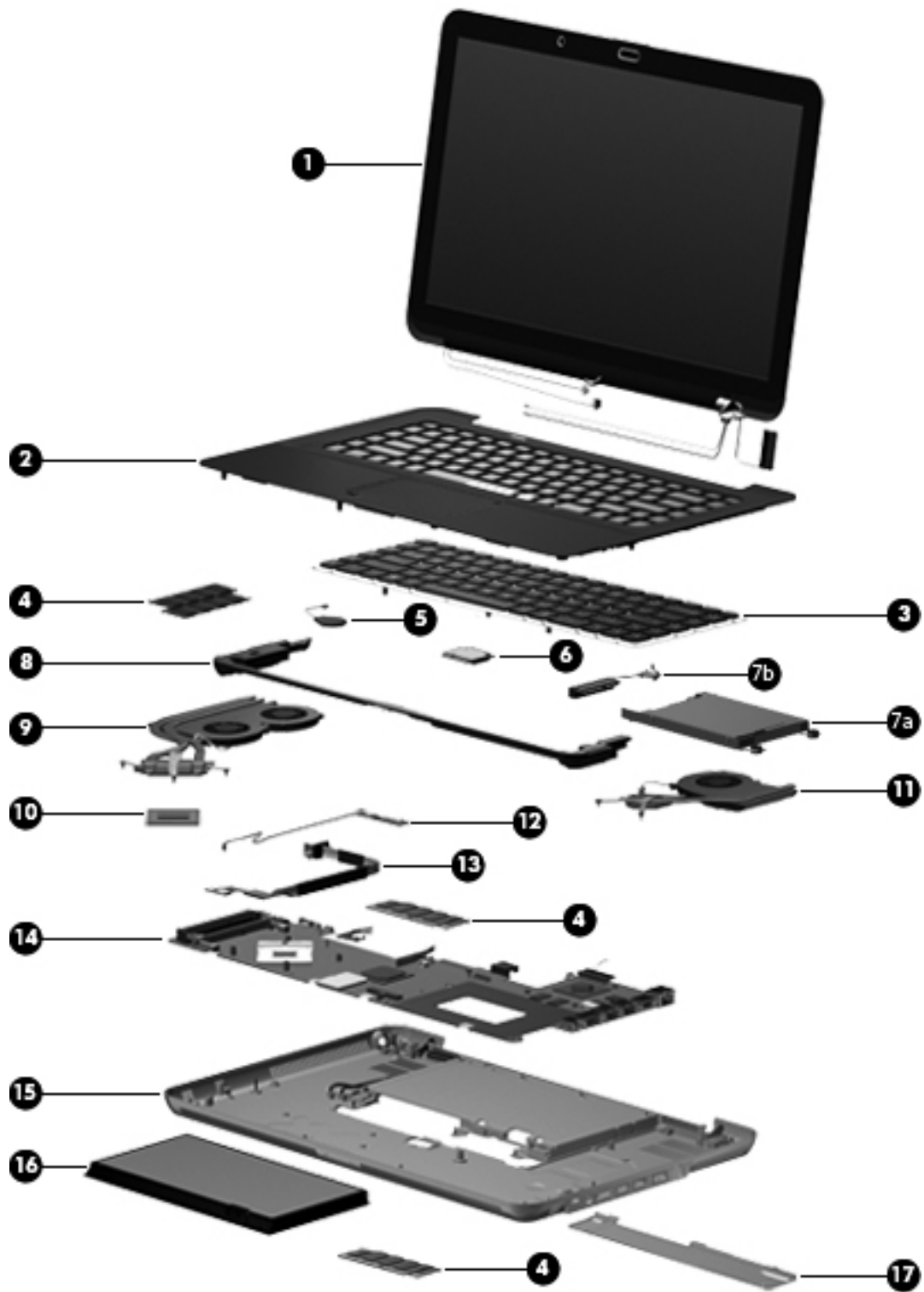

Item	Description	Spare part number
(1)	<b>Display assembly</b> (includes webcam/microphone module and cable, 2 WLAN antenna transceivers and cables, nameplate, and logo):	
	With bronze finish:	
	■ 15.6-in, WVA, AntiGlare LED display assembly	591172-001
	■ 15.6-in, WVA, BrightView LED display assembly	576803-001
	■ 15.6-in, SVA, BrightView LED display assembly	576802-001
	With black finish:	
	■ 15.6-in, WVA, AntiGlare LED display assembly	591173-001
	■ 15.6-in, WVA, BrightView LED display assembly	580127-001
	■ 15.6-in, SVA, BrightView LED display assembly	580126-001
(2)	<b>Top cover</b> (includes TouchPad board, TouchPad bracket, and TouchPad cable):	
	With bronze finish for use in all countries and regions except Brazil and the United Kingdom	576840-001
	With bronze finish for use only in Brazil	576840-201
	With bronze finish for use only in the United Kingdom	576840-031
	With black finish for use in all countries and regions except the United Kingdom	580122-001
	With black finish for use only in the United Kingdom	580122-031
(3)	<b>Keyboard</b> (includes keyboard cable):	
	With bronze finish:	
	■ For use in Belgium	576835-A41
	■ For use in Brazil	576835-201
	■ For use in Denmark, Finland, and Norway	576835-DH1
	■ For use in France	576835-051
	■ For use in French Canada	576835-121
	■ For use in Germany	576835-041
	■ For use in Italy	576835-061
	■ For use in Latin America	576835-161
	■ For use in the Netherlands	576835-B31
	■ For use in Russia	576835-251
	■ For use in Saudi Arabia	576835-171
	■ For use in South Korea	576835-AD1
	■ For use in Spain	576835-071
	■ For use in Switzerland	576835-BG1
	■ For use in the United Kingdom and Singapore	576835-031
	■ For use in the United States	576835-001

*(Continued)*



Item	Description	Spare part number
(3)	<b>Keyboard</b> (includes keyboard cable) <i>(continued)</i> : With black finish:	
	■ For use in France	580132-051
	■ For use in Saudi Arabia	580132-171
	■ For use in the United Kingdom and Singapore	580132-031
	■ For use in the United States	580132-001
	<b>Keyboard Hardware Kit</b> (not illustrated, includes Mylar shield and screws)	576836-001
(4)	<b>Memory modules</b> (1066-MHz, PC3):	
	4096-MB	576817-001
	2048-MB	576816-001
(5)	<b>RTC battery</b> (includes double-sided tape)	576848-001
(6)	<b>WLAN module:</b>	
	802.11 a/g/n WLAN module:	
	■ Intel WiFi Link 6200 802.11 a/g/n WLAN module for use in Andorra, Antigua and Barbuda, Argentina, Aruba, Australia, Austria, Azerbaijan, Bahamas, Bahrain, Barbados, Belgium, Bermuda, Bolivia, Bosnia, Brazil, Brunei, Bulgaria, Canada, the Cayman Islands, Chile, Colombia, Costa Rica, Croatia, Cyprus, the Czech Republic, Denmark, the Dominican Republic, Ecuador, Egypt, El Salvador, Estonia, Finland, France, French Guiana, Georgia, Germany, Ghana, Greece, Guadeloupe, Guam, Guatemala, Haiti, Herzegovina, Honduras, Hong Kong, Hungary, Iceland, India, Indonesia, Ireland, Israel, Italy, the Ivory Coast, Jamaica, Japan, Jordan, Kenya, Kuwait, Kyrgyzstan, Latvia, Lebanon, Liechtenstein, Lithuania, Luxembourg, Malawi, Malaysia, Malta, Martinique, Mauritius, Mexico, Monaco, Montenegro, Morocco, the Nether Antilles, the Netherlands, New Zealand, Nicaragua, Nigeria, Norway, Oman, Panama, Paraguay, the People's Republic China, Peru, the Philippines, Poland, Portugal, Puerto Rico, Qatar, Romania, San Marino, Saudi Arabia, Senegal, Serbia, Singapore, Slovakia, Slovenia, South Africa, South Korea, Spain, Sweden, Switzerland, Taiwan, Tanzania, Thailand, Trinidad and Tobago, Turkey, the United Arab Emirates, the United Kingdom, Uruguay, the U.S. Virgin Islands, the United States, Venezuela, and Vietnam	572509-001
	■ Intel WiFi Link 5100 802.11 a/g/n WLAN module for use in Andorra, Antigua and Barbuda, Argentina, Aruba, Australia, Austria, Azerbaijan, Bahamas, Bahrain, Barbados, Belgium, Bermuda, Bolivia, Bosnia, Brazil, Brunei, Bulgaria, Canada, the Cayman Islands, Chile, Colombia, Costa Rica, Croatia, Cyprus, the Czech Republic, Denmark, the Dominican Republic, Ecuador, Egypt, El Salvador, Estonia, Finland, France, French Guiana, Georgia, Germany, Ghana, Greece, Guadeloupe, Guam, Guatemala, Haiti, Herzegovina, Honduras, Hong Kong, Hungary, Iceland, India, Indonesia, Ireland, Israel, Italy, the Ivory Coast, Jamaica, Japan, Jordan, Kenya, Kuwait, Kyrgyzstan, Latvia, Lebanon, Liechtenstein, Lithuania, Luxembourg, Malawi, Malaysia, Malta, Martinique, Mauritius, Mexico, Monaco, Montenegro, Morocco, the Nether Antilles, the Netherlands, New Zealand, Nicaragua, Nigeria, Norway, Oman, Panama, Paraguay, the People's Republic China, Peru, the Philippines, Poland, Portugal, Puerto Rico, Qatar, Romania, San Marino, Saudi Arabia, Senegal, Serbia, Singapore, Slovakia, Slovenia, South Africa, South Korea, Spain, Sweden, Switzerland, Taiwan, Tanzania, Thailand, Trinidad and Tobago, Turkey, the United Arab Emirates, the United Kingdom, Uruguay, the U.S. Virgin Islands, the United States, Venezuela, and Vietnam	572507-001

*(Continued)*

Item	Description	Spare part number
(6)	<b>WLAN module</b> <i>(continued)</i> :  802.11 a/b/g WLAN module:	
	<ul style="list-style-type: none"> <li>■ Intel WiFi Link 6100 802.11 a/b/g WLAN module for use in Andorra, Antigua and Barbuda, Argentina, Aruba, Australia, Austria, Azerbaijan, Bahamas, Bahrain, Barbados, Belgium, Bermuda, Bolivia, Bosnia, Brazil, Brunei, Bulgaria, Canada, the Cayman Islands, Chile, Colombia, Costa Rica, Croatia, Cyprus, the Czech Republic, Denmark, the Dominican Republic, Ecuador, Egypt, El Salvador, Estonia, Finland, France, French Guiana, Georgia, Germany, Ghana, Greece, Guadeloupe, Guam, Guatemala, Haiti, Herzegovina, Honduras, Hong Kong, Hungary, Iceland, India, Indonesia, Ireland, Israel, Italy, the Ivory Coast, Jamaica, Japan, Jordan, Kenya, Kuwait, Kyrgyzstan, Latvia, Lebanon, Liechtenstein, Lithuania, Luxembourg, Malawi, Malaysia, Malta, Martinique, Mauritius, Mexico, Monaco, Montenegro, Morocco, the Nether Antilles, the Netherlands, New Zealand, Nicaragua, Nigeria, Norway, Oman, Panama, Paraguay, the People's Republic China, Peru, the Philippines, Poland, Portugal, Puerto Rico, Qatar, Romania, San Marino, Saudi Arabia, Senegal, Serbia, Singapore, Slovakia, Slovenia, South Africa, South Korea, Spain, Sweden, Switzerland, Taiwan, Tanzania, Thailand, Trinidad and Tobago, Turkey, the United Arab Emirates, the United Kingdom, Uruguay, the U.S. Virgin Islands, the United States, Venezuela, and Vietnam</li> </ul>	572510-001
	<ul style="list-style-type: none"> <li>■ Intel WiFi Link 5100 802.11 a/b/g WLAN module for use in Andorra, Antigua and Barbuda, Argentina, Aruba, Australia, Austria, Azerbaijan, Bahamas, Bahrain, Barbados, Belgium, Bermuda, Bolivia, Bosnia, Brazil, Brunei, Bulgaria, Canada, the Cayman Islands, Chile, Colombia, Costa Rica, Croatia, Cyprus, the Czech Republic, Denmark, the Dominican Republic, Ecuador, Egypt, El Salvador, Estonia, Finland, France, French Guiana, Georgia, Germany, Ghana, Greece, Guadeloupe, Guam, Guatemala, Haiti, Herzegovina, Honduras, Hong Kong, Hungary, Iceland, India, Indonesia, Ireland, Israel, Italy, the Ivory Coast, Jamaica, Japan, Jordan, Kenya, Kuwait, Kyrgyzstan, Latvia, Lebanon, Liechtenstein, Lithuania, Luxembourg, Malawi, Malaysia, Malta, Martinique, Mauritius, Mexico, Monaco, Montenegro, Morocco, the Nether Antilles, the Netherlands, New Zealand, Nicaragua, Nigeria, Norway, Oman, Panama, Paraguay, the People's Republic China, Peru, the Philippines, Poland, Portugal, Puerto Rico, Qatar, Romania, San Marino, Saudi Arabia, Senegal, Serbia, Singapore, Slovakia, Slovenia, South Africa, South Korea, Spain, Sweden, Switzerland, Taiwan, Tanzania, Thailand, Trinidad and Tobago, Turkey, the United Arab Emirates, the United Kingdom, Uruguay, the U.S. Virgin Islands, the United States, Venezuela, and Vietnam</li> </ul>	572508-001
	<p>Intel 1000 802.11 b/g/n WLAN module for use in Andorra, Antigua and Barbuda, Argentina, Aruba, Australia, Austria, Azerbaijan, Bahamas, Bahrain, Barbados, Belgium, Bermuda, Bolivia, Bosnia, Brazil, Brunei, Bulgaria, Canada, the Cayman Islands, Chile, Colombia, Costa Rica, Croatia, Cyprus, the Czech Republic, Denmark, the Dominican Republic, Ecuador, Egypt, El Salvador, Estonia, Finland, France, French Guiana, Georgia, Germany, Ghana, Greece, Guadeloupe, Guam, Guatemala, Haiti, Herzegovina, Honduras, Hong Kong, Hungary, Iceland, India, Indonesia, Ireland, Israel, Italy, the Ivory Coast, Jamaica, Japan, Jordan, Kenya, Kuwait, Kyrgyzstan, Latvia, Lebanon, Liechtenstein, Lithuania, Luxembourg, Malawi, Malaysia, Malta, Martinique, Mauritius, Mexico, Monaco, Montenegro, Morocco, the Nether Antilles, the Netherlands, New Zealand, Nicaragua, Nigeria, Norway, Oman, Panama, Paraguay, the People's Republic China, Peru, the Philippines, Poland, Portugal, Puerto Rico, Qatar, Romania, San Marino, Saudi Arabia, Senegal, Serbia, Singapore, Slovakia, Slovenia, South Africa, South Korea, Spain, Sweden, Switzerland, Taiwan, Tanzania, Thailand, Trinidad and Tobago, Turkey, the United Arab Emirates, the United Kingdom, Uruguay, the U.S. Virgin Islands, the United States, Venezuela, and Vietnam</p>	572520-001

*(Continued)*

Item	Description	Spare part number
(6)	<b>WLAN module</b> (continued): Intel 1000 802.11 b/g WLAN module for use in Andorra, Antigua and Barbuda, Argentina, Aruba, Australia, Austria, Azerbaijan, Bahamas, Bahrain, Barbados, Belgium, Bermuda, Bolivia, Bosnia, Brazil, Brunei, Bulgaria, Canada, the Cayman Islands, Chile, Colombia, Costa Rica, Croatia, Cyprus, the Czech Republic, Denmark, the Dominican Republic, Ecuador, Egypt, El Salvador, Estonia, Finland, France, French Guiana, Georgia, Germany, Ghana, Greece, Guadeloupe, Guam, Guatemala, Haiti, Herzegovina, Honduras, Hong Kong, Hungary, Iceland, India, Indonesia, Ireland, Israel, Italy, the Ivory Coast, Jamaica, Japan, Jordan, Kenya, Kuwait, Kyrgyzstan, Latvia, Lebanon, Liechtenstein, Lithuania, Luxembourg, Malawi, Malaysia, Malta, Martinique, Mauritius, Mexico, Monaco, Montenegro, Morocco, the Nether Antilles, the Netherlands, New Zealand, Nicaragua, Nigeria, Norway, Oman, Panama, Paraguay, the People's Republic China, Peru, the Philippines, Poland, Portugal, Puerto Rico, Qatar, Romania, San Marino, Saudi Arabia, Senegal, Serbia, Singapore, Slovakia, Slovenia, South Africa, South Korea, Spain, Sweden, Switzerland, Taiwan, Tanzania, Thailand, Trinidad and Tobago, Turkey, the United Arab Emirates, the United Kingdom, Uruguay, the U.S. Virgin Islands, the United States, Venezuela, and Vietnam	585984-001
(7a)	<b>Hard drive</b> (includes bracket, rubber isolators, and screws): 2.5-in, 7200-rpm: ■ 640-GB ■ 500-GB ■ 320-GB ■ 250-GB 1.8-in, 5400-rpm: ■ 320-GB ■ 250-GB ■ 160-GB	576821-001 576820-001 576819-001 576818-001 576823-001 580129-001 591171-001
(7b)	<b>Hard drive cable:</b> For use only with 2.5-in hard drives For use only with 1.8-in hard drives <b>Hard Drive Hardware Kit</b> (not illustrated, includes bracket, rubber isolators, and screws): For use only with 2.5-in hard drives For use only with 1.8-in hard drives	576828-001 576830-001 576827-001 576829-001
(8)	<b>Speaker assembly</b>	576842-001
(9)	<b>Processor fan/heat sink assembly</b> (includes replacement thermal material)	576837-001
(10)	<b>Processor</b> (includes replacement thermal material): Intel Core i7-820QM 1.73-GHz processor (SC turbo up to 3.06-GHz) Intel Core i7-720QM 1.60-GHz processor (SC turbo up to 2.80-GHz)	583053-001 586170-001
(11)	<b>Video fan/heat sink assembly</b> (includes replacement thermal material)	576838-001
(12)	<b>Power button board and cable</b> (includes double-sided tape)	576849-001
(13)	<b>Power connector cable</b> (includes bracket)	576846-001

(Continued)

Item	Description	Spare part number
(14)	<b>PM57 PCH Peak-M system board with 1 GB of dedicated video memory</b> (includes replacement thermal material)	576772-001
(15)	<b>Base enclosure</b> (includes 4 rubber feet):	
	With bronze finish	576839-001
	With black finish	580121-001
	<b>Rubber Feet Kit</b> (not illustrated, includes 4 rubber feet)	538346-001
(16)	<b>Battery:</b>	
	9-cell, 2.80-Ah (93-Wh) Li-ion battery	576834-001
	6-cell, 2.40-Ah (53-Wh) Li-ion battery	576833-001 and 586025-001
(17)	<b>Memory module compartment cover</b> (included in the Plastics Kit, spare part number 576847-001)	

## Display components

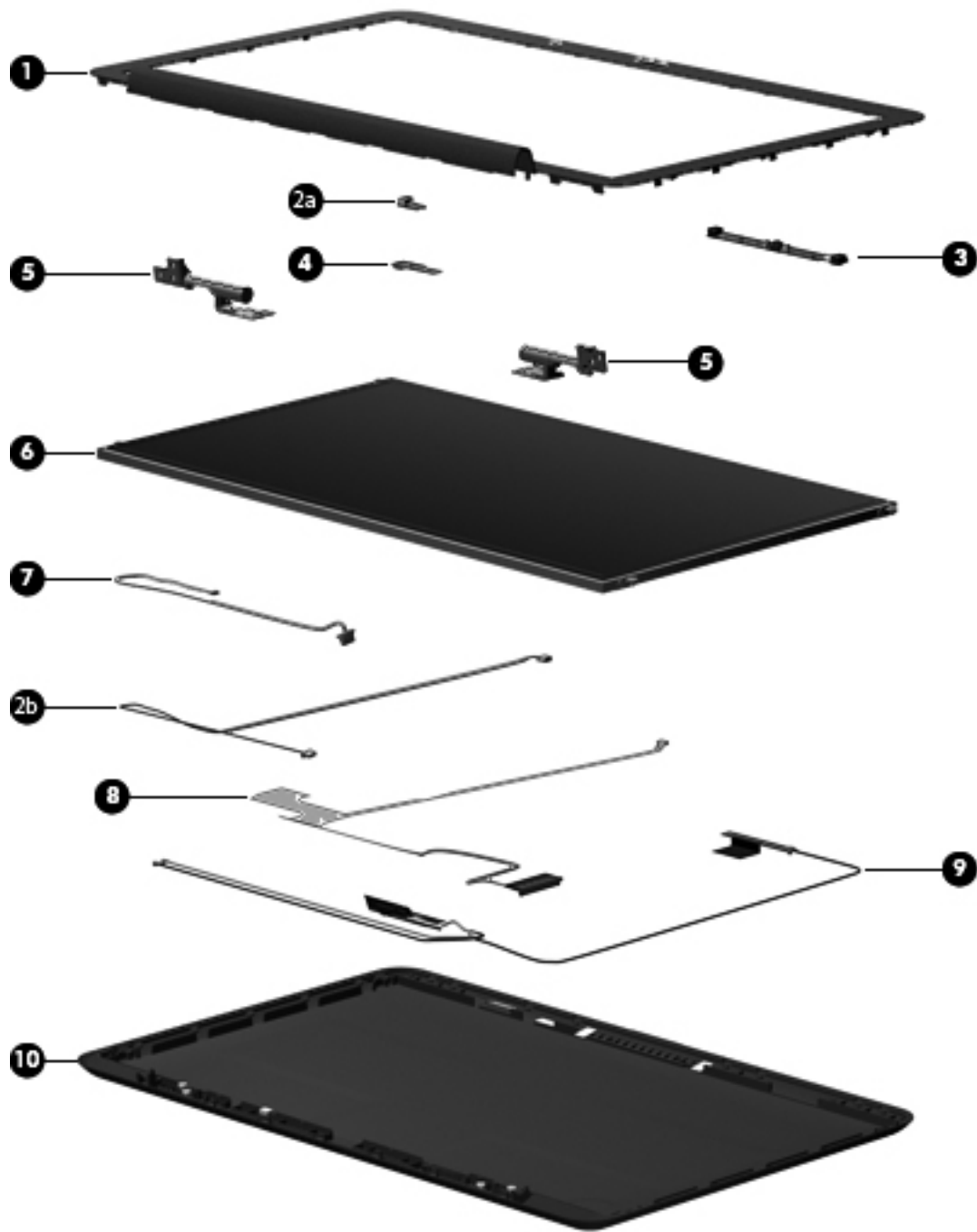

Item	Description	Spare part number
(1)	<b>Display bezel</b>	576810-001
(2a)	<b>Ambient light sensor module</b> (includes cable and double-sided tape)	576815-001
(2b)	<b>Ambient light sensor module cable</b> (included in the ambient light sensor module spare part kit)	
(3)	<b>Webcam/microphone module</b>	576812-001
(4)	<b>Bluetooth module</b>	537921-001
	 The Bluetooth module spare part kit does not include a Bluetooth module cable. The Bluetooth module cable is available using spare part number 576845-001.	
(5)	<b>Display left and right hinges</b> (included in the Display Hinge Kit, spare part number 576809-001)	
(6)	<b>Display panel:</b>	
	For use only with the 15.6-in, WVA, AntiGlare LED display assembly	591327-001
	For use only with the 15.6-in, WVA, BrightView LED display assembly	576801-001
	For use only with the 15.6-in, SVA, BrightView LED display assembly	576800-001
(7)	<b>Bluetooth module cable</b>	576845-001
(8)	<b>Display panel cable</b> (includes double-sided tape)	576813-001
(9)	<b>Wireless antenna transceivers and cables</b>	576814-001
(10)	<b>Display enclosure:</b>	
	With bronze finish	576811-001
	With black finish	580128-001
	<b>Display Screw Kit</b> (not illustrated)	576808-001

## Mass storage devices



Item	Description	Spare part number
(1)	<b>Hard drive</b> (includes bracket, rubber isolators, and screws):	
	2.5-in, 7200-rpm:	
	■ 640-GB	576821-001
	■ 500-GB	576820-001
	■ 320-GB	576819-001
	■ 250-GB	576818-001
	1.8-in, 5400-rpm:	
	■ 320-GB	576823-001
	■ 250-GB	580129-001
	■ 160-GB	591171-001
(2)	<b>Hard drive cable:</b>	
	For use only with 2.5-in hard drives	576828-001
	For use only with 1.8-in hard drives	576830-001
	<b>Hard Drive Hardware Kit</b> (not illustrated, includes bracket, rubber isolators, and screws):	
	For use only with 2.5-in hard drives	576827-001
For use only with 1.8-in hard drives	576829-001	
(3)	<b>External optical drive:</b>	
	With bronze finish:	
	■ Blu-ray ROM with LightScribe DVD±R/RW SuperMulti Double-Layer Drive	576832-001
	■ DVD±RW and CD-RW SuperMulti Double-Layer Combo Drive with LightScribe	576831-001
	With black finish:	
	■ Blu-ray ROM with LightScribe DVD±R/RW SuperMulti Double-Layer Drive	580131-001
■ DVD±RW and CD-RW SuperMulti Double-Layer Combo Drive with LightScribe	580130-001	



## Miscellaneous parts

Description	Spare part number
<b>AC adapter:</b>	
120-W PFC HP Smart Adapter	463953-001
90-W PFC HP Smart Adapter	463955-001
<b>HDMI-to-VGA adapter</b>	530607-001
<b>HP Notebook protective case:</b>	
For use with computer models with bronze finish	578252-001
For use with computer models with black finish	580792-001
<b>Power cord:</b>	
For use in Australia	490371-011
For use in Brazil	490371-201 and 490371-202
For use in Canada, Mexico, and the United States	490371-001
For use in Europe, the Middle East, and Africa	490371-021
For use in India	490371-D61
For use in Italy	490371-061
For use in the People's Republic of China	490371-AA1
For use in South Korea	490371-AD1
For use in Switzerland	490371-111
For use in the United Kingdom and Singapore	490371-031
<b>Screw Kit:</b>	576844-001
Phillips PM3.0x4.0 screw	
Phillips PM2.5x6.0 screw	
Phillips PM2.0x12.0 screw	
Phillips PM2.0x6.0 captive screw	
Phillips PM2.0x5.0 screw	
Phillips PM2.0x4.0 broadhead screw	
Phillips PM2.0x4.0 screw	
Phillips PM2.0x3.0 screw	
Phillips PM2.0x2.0 screw	
Phillips PM1.5x1.5 screw	

## Sequential part number listing

Spare part number	Description
463953-001	120-W PFC HP Smart Adapter
463955-001	90-W PFC HP Smart Adapter
490371-001	Power cord for use in Canada, Mexico, and the United States
490371-011	Power cord for use in Australia
490371-021	Power cord for use in Europe, the Middle East, and Africa
490371-031	Power cord for use in the United Kingdom and Singapore
490371-061	Power cord for use in Italy
490371-111	Power cord for use in Switzerland
490371-201	Power cord for use in Brazil
490371-202	Power cord for use in Brazil
490371-AA1	Power cord for use in the People's Republic of China
490371-AD1	Power cord for use in South Korea
490371-D61	Power cord for use in India
530607-001	HDMI-to-VGA adapter
537921-001	Bluetooth module  The Bluetooth module spare part kit does not include a Bluetooth module cable. The Bluetooth module cable is available using spare part number 576845-001.
538346-001	Rubber Feet Kit (includes 4 rubber feet)
572507-001	Intel WiFi Link 5100 802.11 a/g/n WLAN module for use in Andorra, Antigua and Barbuda, Argentina, Aruba, Australia, Austria, Azerbaijan, Bahamas, Bahrain, Barbados, Belgium, Bermuda, Bolivia, Bosnia, Brazil, Brunei, Bulgaria, Canada, the Cayman Islands, Chile, Colombia, Costa Rica, Croatia, Cyprus, the Czech Republic, Denmark, the Dominican Republic, Ecuador, Egypt, El Salvador, Estonia, Finland, France, French Guiana, Georgia, Germany, Ghana, Greece, Guadeloupe, Guam, Guatemala, Haiti, Herzegovina, Honduras, Hong Kong, Hungary, Iceland, India, Indonesia, Ireland, Israel, Italy, the Ivory Coast, Jamaica, Japan, Jordan, Kenya, Kuwait, Kyrgyzstan, Latvia, Lebanon, Liechtenstein, Lithuania, Luxembourg, Malawi, Malaysia, Malta, Martinique, Mauritius, Mexico, Monaco, Montenegro, Morocco, the Nether Antilles, the Netherlands, New Zealand, Nicaragua, Nigeria, Norway, Oman, Panama, Paraguay, the People's Republic China, Peru, the Philippines, Poland, Portugal, Puerto Rico, Qatar, Romania, San Marino, Saudi Arabia, Senegal, Serbia, Singapore, Slovakia, Slovenia, South Africa, South Korea, Spain, Sweden, Switzerland, Taiwan, Tanzania, Thailand, Trinidad and Tobago, Turkey, the United Arab Emirates, the United Kingdom, Uruguay, the U.S. Virgin Islands, the United States, Venezuela, and Vietnam
572508-001	Intel WiFi Link 5100 802.11 a/b/g WLAN module for use in Andorra, Antigua and Barbuda, Argentina, Aruba, Australia, Austria, Azerbaijan, Bahamas, Bahrain, Barbados, Belgium, Bermuda, Bolivia, Bosnia, Brazil, Brunei, Bulgaria, Canada, the Cayman Islands, Chile, Colombia, Costa Rica, Croatia, Cyprus, the Czech Republic, Denmark, the Dominican Republic, Ecuador, Egypt, El Salvador, Estonia, Finland, France, French Guiana, Georgia, Germany, Ghana, Greece, Guadeloupe, Guam, Guatemala, Haiti, Herzegovina, Honduras, Hong Kong, Hungary, Iceland, India, Indonesia, Ireland, Israel, Italy, the Ivory Coast, Jamaica, Japan, Jordan, Kenya, Kuwait, Kyrgyzstan, Latvia, Lebanon, Liechtenstein, Lithuania, Luxembourg, Malawi, Malaysia, Malta, Martinique, Mauritius, Mexico, Monaco, Montenegro, Morocco, the Nether Antilles, the Netherlands, New Zealand, Nicaragua, Nigeria, Norway, Oman, Panama, Paraguay, the People's Republic China, Peru, the Philippines, Poland, Portugal, Puerto Rico, Qatar, Romania, San Marino, Saudi Arabia, Senegal, Serbia, Singapore, Slovakia, Slovenia, South Africa, South Korea, Spain, Sweden, Switzerland, Taiwan, Tanzania, Thailand, Trinidad and Tobago, Turkey, the United Arab Emirates, the United Kingdom, Uruguay, the U.S. Virgin Islands, the United States, Venezuela, and Vietnam

(Continued)

Spare part number	Description
572509-001	Intel WiFi Link 6200 802.11 a/g/n WLAN module for use in Andorra, Antigua and Barbuda, Argentina, Aruba, Australia, Austria, Azerbaijan, Bahamas, Bahrain, Barbados, Belgium, Bermuda, Bolivia, Bosnia, Brazil, Brunei, Bulgaria, Canada, the Cayman Islands, Chile, Colombia, Costa Rica, Croatia, Cyprus, the Czech Republic, Denmark, the Dominican Republic, Ecuador, Egypt, El Salvador, Estonia, Finland, France, French Guiana, Georgia, Germany, Ghana, Greece, Guadeloupe, Guam, Guatemala, Haiti, Herzegovina, Honduras, Hong Kong, Hungary, Iceland, India, Indonesia, Ireland, Israel, Italy, the Ivory Coast, Jamaica, Japan, Jordan, Kenya, Kuwait, Kyrgyzstan, Latvia, Lebanon, Liechtenstein, Lithuania, Luxembourg, Malawi, Malaysia, Malta, Martinique, Mauritius, Mexico, Monaco, Montenegro, Morocco, the Nether Antilles, the Netherlands, New Zealand, Nicaragua, Nigeria, Norway, Oman, Panama, Paraguay, the People's Republic China, Peru, the Philippines, Poland, Portugal, Puerto Rico, Qatar, Romania, San Marino, Saudi Arabia, Senegal, Serbia, Singapore, Slovakia, Slovenia, South Africa, South Korea, Spain, Sweden, Switzerland, Taiwan, Tanzania, Thailand, Trinidad and Tobago, Turkey, the United Arab Emirates, the United Kingdom, Uruguay, the U.S. Virgin Islands, the United States, Venezuela, and Vietnam
572510-001	Intel WiFi Link 6100 802.11 a/b/g WLAN module for use in Andorra, Antigua and Barbuda, Argentina, Aruba, Australia, Austria, Azerbaijan, Bahamas, Bahrain, Barbados, Belgium, Bermuda, Bolivia, Bosnia, Brazil, Brunei, Bulgaria, Canada, the Cayman Islands, Chile, Colombia, Costa Rica, Croatia, Cyprus, the Czech Republic, Denmark, the Dominican Republic, Ecuador, Egypt, El Salvador, Estonia, Finland, France, French Guiana, Georgia, Germany, Ghana, Greece, Guadeloupe, Guam, Guatemala, Haiti, Herzegovina, Honduras, Hong Kong, Hungary, Iceland, India, Indonesia, Ireland, Israel, Italy, the Ivory Coast, Jamaica, Japan, Jordan, Kenya, Kuwait, Kyrgyzstan, Latvia, Lebanon, Liechtenstein, Lithuania, Luxembourg, Malawi, Malaysia, Malta, Martinique, Mauritius, Mexico, Monaco, Montenegro, Morocco, the Nether Antilles, the Netherlands, New Zealand, Nicaragua, Nigeria, Norway, Oman, Panama, Paraguay, the People's Republic China, Peru, the Philippines, Poland, Portugal, Puerto Rico, Qatar, Romania, San Marino, Saudi Arabia, Senegal, Serbia, Singapore, Slovakia, Slovenia, South Africa, South Korea, Spain, Sweden, Switzerland, Taiwan, Tanzania, Thailand, Trinidad and Tobago, Turkey, the United Arab Emirates, the United Kingdom, Uruguay, the U.S. Virgin Islands, the United States, Venezuela, and Vietnam
572520-001	Intel 1000 802.11 b/g/n WLAN module for use in Andorra, Antigua and Barbuda, Argentina, Aruba, Australia, Austria, Azerbaijan, Bahamas, Bahrain, Barbados, Belgium, Bermuda, Bolivia, Bosnia, Brazil, Brunei, Bulgaria, Canada, the Cayman Islands, Chile, Colombia, Costa Rica, Croatia, Cyprus, the Czech Republic, Denmark, the Dominican Republic, Ecuador, Egypt, El Salvador, Estonia, Finland, France, French Guiana, Georgia, Germany, Ghana, Greece, Guadeloupe, Guam, Guatemala, Haiti, Herzegovina, Honduras, Hong Kong, Hungary, Iceland, India, Indonesia, Ireland, Israel, Italy, the Ivory Coast, Jamaica, Japan, Jordan, Kenya, Kuwait, Kyrgyzstan, Latvia, Lebanon, Liechtenstein, Lithuania, Luxembourg, Malawi, Malaysia, Malta, Martinique, Mauritius, Mexico, Monaco, Montenegro, Morocco, the Nether Antilles, the Netherlands, New Zealand, Nicaragua, Nigeria, Norway, Oman, Panama, Paraguay, the People's Republic China, Peru, the Philippines, Poland, Portugal, Puerto Rico, Qatar, Romania, San Marino, Saudi Arabia, Senegal, Serbia, Singapore, Slovakia, Slovenia, South Africa, South Korea, Spain, Sweden, Switzerland, Taiwan, Tanzania, Thailand, Trinidad and Tobago, Turkey, the United Arab Emirates, the United Kingdom, Uruguay, the U.S. Virgin Islands, the United States, Venezuela, and Vietnam
576772-001	PM57 PCH Peak-M system board with 1 GB of dedicated video memory (includes replacement thermal material)
576800-001	Display panel for use only with the 15.6-in, SVA, BrightView LED display assembly
576801-001	Display panel for use only with the 15.6-in, WVA, BrightView LED display assembly
576802-001	15.6-in, SVA, BrightView LED display assembly with bronze finish (includes webcam/microphone module and cable, 2 WLAN antenna transceivers and cables, nameplate, and logo)
576803-001	15.6-in, WVA, BrightView LED display assembly with bronze finish (includes webcam/microphone module and cable, 2 WLAN antenna transceivers and cables, nameplate, and logo)
576808-001	Display Screw Kit
576809-001	Display Hinge Kit (includes the left and right display hinges)
576810-001	Display bezel
576811-001	Display enclosure with bronze finish

(Continued)

<b>Spare part number</b>	<b>Description</b>
576812-001	Webcam/microphone module
576813-001	Display panel cable (includes double-sided tape)
576814-001	Wireless antenna transceivers and cables
576815-001	Ambient light sensor module (includes cable and double-sided tape)
576816-001	2048-MB memory module (1066-MHz, PC3)
576817-001	4096-MB memory module (1066-MHz, PC3)
576818-001	250-GB, 2.5-in, 7200-rpm hard drive (includes bracket, rubber isolators, and screws)
576819-001	320-GB, 2.5-in, 7200-rpm hard drive (includes bracket, rubber isolators, and screws)
576820-001	500-GB, 2.5-in, 7200-rpm hard drive (includes bracket, rubber isolators, and screws)
576821-001	640-GB, 2.5-in, 7200-rpm hard drive (includes bracket, rubber isolators, and screws)
576823-001	320-GB, 1.8-in, 5400-rpm hard drive (includes bracket, rubber isolators, and screws)
576827-001	Hard Drive Hardware Kit for use only with 2.5-in hard drives (includes bracket, rubber isolators, and screws)
576828-001	Hard drive cable for use only with 2.5-in hard drives
576829-001	Hard Drive Hardware Kit for use only with 1.8-in hard drives (includes bracket, rubber isolators, and screws)
576830-001	Hard drive cable for use only with 1.8-in hard drives
576831-001	DVD±RW and CD-RW SuperMulti Double-Layer Combo Drive with LightScribe with bronze finish
576832-001	Blu-ray ROM with LightScribe DVD±R/RW SuperMulti Double-Layer Drive with bronze finish
576833-001	6-cell, 2.40-Ah (53-Wh) Li-ion battery
576834-001	9-cell, 2.80-Ah (93-Wh) Li-ion battery
576835-001	Keyboard with bronze finish for use in the United States (includes keyboard cable)
576835-031	Keyboard with bronze finish for use in the United Kingdom and Singapore (includes keyboard cable)
576835-041	Keyboard with bronze finish for use in Germany (includes keyboard cable)
576835-051	Keyboard with bronze finish for use in France (includes keyboard cable)
576835-061	Keyboard with bronze finish for use in Italy (includes keyboard cable)
576835-071	Keyboard with bronze finish for use in Spain (includes keyboard cable)
576835-121	Keyboard with bronze finish for use in French Canada (includes keyboard cable)
576835-161	Keyboard with bronze finish for use in Latin America (includes keyboard cable)
576835-171	Keyboard with bronze finish for use in Saudi Arabia (includes keyboard cable)
576835-201	Keyboard with bronze finish for use in Brazil (includes keyboard cable)
576835-251	Keyboard with bronze finish for use in Russia (includes keyboard cable)
576835-A41	Keyboard with bronze finish for use in Belgium (includes keyboard cable)
576835-AD1	Keyboard with bronze finish for use in South Korea (includes keyboard cable)
576835-B31	Keyboard with bronze finish for use in the Netherlands (includes keyboard cable)
576835-BG1	Keyboard with bronze finish for use in Switzerland (includes keyboard cable)
576835-DH1	Keyboard with bronze finish for use in Denmark, Finland, and Norway (includes keyboard cable)
576836-001	Keyboard Hardware Kit (includes Mylar shield and screws)
576837-001	Processor fan/heat sink assembly (includes replacement thermal material)

*(Continued)*

<b>Spare part number</b>	<b>Description</b>
576838-001	Video fan/heat sink assembly (includes replacement thermal material)
576839-001	Base enclosure with bronze finish (includes 4 rubber feet)
576840-001	Top cover with bronze finish for use in all countries and regions except Brazil and the United Kingdom (includes TouchPad board, TouchPad bracket, and TouchPad cable)
576840-031	Top cover with bronze finish for use only in the United Kingdom (includes TouchPad board, TouchPad bracket, and TouchPad cable)
576840-201	Top cover with bronze finish for use only in Brazil (includes TouchPad board, TouchPad bracket, and TouchPad cable)
576842-001	Speaker assembly
576844-001	Screw Kit
576845-001	Bluetooth module cable
576846-001	Power connector cable (includes bracket)
576847-001	Plastics Kit (includes the memory module compartment cover)
576848-001	RTC battery (includes double-sided tape)
576849-001	Power button board and cable (includes double-sided tape)
578252-001	HP Notebook protective case for use with computer models with bronze finish
580121-001	Base enclosure with black finish (includes 4 rubber feet)
580122-001	Top cover with black finish for use in all countries and regions except the United Kingdom (includes TouchPad board, TouchPad bracket, and TouchPad cable)
580122-031	Top cover with black finish for use only in the United Kingdom (includes TouchPad board, TouchPad bracket, and TouchPad cable)
580126-001	15.6-in, SVA, BrightView LED display assembly with black finish (includes webcam/microphone module and cable, 2 WLAN antenna transceivers and cables, nameplate, and logo)
580127-001	15.6-in, WVA, BrightView LED display assembly with black finish (includes webcam/microphone module and cable, 2 WLAN antenna transceivers and cables, nameplate, and logo)
580128-001	Display enclosure with black finish
580129-001	250-GB, 1.8-in, 5400-rpm hard drive (includes bracket, rubber isolators, and screws)
580130-001	DVD±RW and CD-RW SuperMulti Double-Layer Combo Drive with LightScribe with black finish
580131-001	Blu-ray ROM with LightScribe DVD±R/RW SuperMulti Double-Layer Drive with black finish
580132-001	Keyboard with black finish for use in the United States (includes keyboard cable)
580132-031	Keyboard with black finish for use in the United Kingdom and Singapore (includes keyboard cable)
580132-051	Keyboard with black finish for use in France (includes keyboard cable)
580132-171	Keyboard with black finish for use in Saudi Arabia (includes keyboard cable)
580792-001	HP Notebook protective case for use with computer models with black finish
583053-001	Intel Core i7-820QM 1.73-GHz processor (SC turbo up to 3.06-GHz, includes replacement thermal material)

*(Continued)*

Spare part number	Description
585984-001	Intel 1000 802.11 b/g WLAN module for use in Andorra, Antigua and Barbuda, Argentina, Aruba, Australia, Austria, Azerbaijan, Bahamas, Bahrain, Barbados, Belgium, Bermuda, Bolivia, Bosnia, Brazil, Brunei, Bulgaria, Canada, the Cayman Islands, Chile, Colombia, Costa Rica, Croatia, Cyprus, the Czech Republic, Denmark, the Dominican Republic, Ecuador, Egypt, El Salvador, Estonia, Finland, France, French Guiana, Georgia, Germany, Ghana, Greece, Guadeloupe, Guam, Guatemala, Haiti, Herzegovina, Honduras, Hong Kong, Hungary, Iceland, India, Indonesia, Ireland, Israel, Italy, the Ivory Coast, Jamaica, Japan, Jordan, Kenya, Kuwait, Kyrgyzstan, Latvia, Lebanon, Liechtenstein, Lithuania, Luxembourg, Malawi, Malaysia, Malta, Martinique, Mauritius, Mexico, Monaco, Montenegro, Morocco, the Nether Antilles, the Netherlands, New Zealand, Nicaragua, Nigeria, Norway, Oman, Panama, Paraguay, the People's Republic China, Peru, the Philippines, Poland, Portugal, Puerto Rico, Qatar, Romania, San Marino, Saudi Arabia, Senegal, Serbia, Singapore, Slovakia, Slovenia, South Africa, South Korea, Spain, Sweden, Switzerland, Taiwan, Tanzania, Thailand, Trinidad and Tobago, Turkey, the United Arab Emirates, the United Kingdom, Uruguay, the U.S. Virgin Islands, the United States, Venezuela, and Vietnam
586025-001	6-cell, 2.40-Ah (53-Wh) Li-ion battery
586170-001	Intel Core i7-720QM 1.60-GHz processor (SC turbo up to 2.80-GHz, includes replacement thermal material)
591171-001	160-GB, 1.8-in, 5400-rpm hard drive (includes bracket, rubber isolators, and screws)
591172-001	15.6-in, WVA, AntiGlare LED display assembly with bronze finish (includes webcam/microphone module and cable, 2 WLAN antenna transceivers and cables, nameplate, and logo)
591173-001	15.6-in, WVA, AntiGlare LED display assembly with black finish (includes webcam/microphone module and cable, 2 WLAN antenna transceivers and cables, nameplate, and logo)
591327-001	Display panel for use only with the 15.6-in, WVA, AntiGlare LED display assembly

---

# Removal and replacement procedures

## Preliminary replacement requirements

### Tools required

You will need the following tools to complete the removal and replacement procedures:

- Flat-bladed screwdriver
- Phillips P1, P0, and P00 screwdrivers

### Service considerations

The following sections include some of the considerations that you must keep in mind during disassembly and assembly procedures.



---

As you remove each subassembly from the computer, place the subassembly (and all accompanying screws) away from the work area to prevent damage.

---

### Plastic parts



---

**CAUTION:** Using excessive force during disassembly and reassembly can damage plastic parts. Use care when handling the plastic parts. Apply pressure only at the points designated in the maintenance instructions.

---

### Cables and connectors



---

**CAUTION:** When servicing the computer, be sure that cables are placed in their proper locations during the reassembly process. Improper cable placement can damage the computer.

---

Cables must be handled with extreme care to avoid damage. Apply only the tension required to unseat or seat the cables during removal and insertion. Handle cables by the connector whenever possible. In all cases, avoid bending, twisting, or tearing cables. Be sure that cables are routed in such a way that they cannot be caught or snagged by parts being removed or replaced. Handle flex cables with extreme care; these cables tear easily.

## Drive handling



**CAUTION:** Drives are fragile components that must be handled with care. To prevent damage to the computer, damage to a drive, or loss of information, observe these precautions:

- Before removing or inserting a mass storage device, shut down the computer.
  - Before handling a drive, be sure that you are discharged of static electricity. While handling a drive, avoid touching the connector.
  - Before removing a diskette drive or optical drive, be sure that a diskette or disc is not in the drive and be sure that the optical drive tray is closed.
  - Handle drives on surfaces covered with at least one inch of shock-proof foam.
  - Avoid dropping drives from any height onto any surface.
  - After removing a mass storage device, an optical drive, or a diskette drive, place it in a static-proof bag.
  - Avoid exposing a mass storage device to products that have magnetic fields, such as monitors or speakers.
  - Avoid exposing a drive to temperature extremes or liquids.
  - If a drive must be mailed, place the drive in a bubble pack mailer or other suitable form of protective packaging and label the package "FRAGILE."
- 

## Grounding guidelines

### Electrostatic discharge damage

Electronic components are sensitive to electrostatic discharge (ESD). Circuitry design and structure determine the degree of sensitivity. Networks built into many integrated circuits provide some protection, but in many cases, ESD contains enough power to alter device parameters or melt silicon junctions.

A discharge of static electricity from a finger or other conductor can destroy static-sensitive devices or microcircuitry. Even if the spark is neither felt nor heard, damage may have occurred.

An electronic device exposed to ESD may not be affected at all and may work perfectly throughout a normal cycle. Or, the device may function normally for a while, and then degrade in the internal layers, reducing its life expectancy.



**CAUTION:** To prevent damage to the computer when you are removing or installing internal components, observe these precautions:

- Keep components in their electrostatic-safe containers until you are ready to install them.
  - Use nonmagnetic tools.
  - Before touching an electronic component, discharge static electricity by using the guidelines described in this section.
  - Avoid touching pins, leads, and circuitry. Handle electronic components as little as possible.
  - If you remove a component, place it in an electrostatic-safe container.
-



The following table shows how humidity affects the electrostatic voltage levels generated by different activities.



**CAUTION:** A product can be degraded by as little as 700 V.

Typical electrostatic voltage levels			
Event	Relative humidity		
	10%	40%	55%
Walking across carpet	35,000 V	15,000 V	7,500 V
Walking across vinyl floor	12,000 V	5,000 V	3,000 V
Motions of bench worker	6,000 V	800 V	400 V
Removing DIPS from plastic tube	2,000 V	700 V	400 V
Removing DIPS from vinyl tray	11,500 V	4,000 V	2,000 V
Removing DIPS from Styrofoam	14,500 V	5,000 V	3,500 V
Removing bubble pack from PCB	26,500 V	20,000 V	7,000 V
Packing PCBs in foam-lined box	21,000 V	11,000 V	5,000 V

## Packaging and transporting guidelines

Follow these grounding guidelines when packaging and transporting equipment:

- To avoid hand contact, transport products in static-safe tubes, bags, or boxes.
- Protect ESD-sensitive parts and assemblies with conductive or approved containers or packaging.
- Keep ESD-sensitive parts in their containers until they arrive at static-free workstations.
- Place items on a grounded surface before removing them from their containers.
- Always be properly grounded when touching a component or assembly.
- Store reusable ESD-sensitive parts from assemblies in protective packaging or nonconductive foam.
- Use transporters and conveyors made of antistatic belts and roller bushings. Be sure that mechanized equipment used for moving materials is wired to ground, and that proper materials are selected to avoid static charging. When grounding is not possible, use an ionizer to dissipate electric charges.

## Workstation guidelines

Follow these workstation grounding guidelines:

- Cover the workstation with approved static-shielding material.
- Use a wrist strap connected to a properly grounded work surface, and use properly grounded tools and equipment.
- Use conductive field service tools, such as cutters, screwdrivers, and vacuums.
- When fixtures must directly contact dissipative surfaces, use fixtures made only of static-safe materials.
- Keep the work area free of nonconductive materials, such as ordinary plastic assembly aids and Styrofoam.
- Handle ESD-sensitive components, parts, and assemblies by the case or PCM laminate. Handle these items only at static-free workstations.
- Avoid contact with pins, leads, or circuitry.
- Turn off power and input signals before inserting or removing connectors or test equipment.

## Equipment guidelines

Grounding equipment must include either a wrist strap or a foot strap at a grounded workstation.

- When seated, wear a wrist strap connected to a grounded system. Wrist straps are flexible straps with a minimum of one megohm  $\pm 10\%$  resistance in the ground cords. To provide proper ground, wear a strap snugly against the skin at all times. On grounded mats with banana-plug connectors, use alligator clips to connect a wrist strap.
- When standing, use foot straps and a grounded floor mat. Foot straps (heel, toe, or boot straps) can be used at standing workstations and are compatible with most types of shoes or boots. On conductive floors or dissipative floor mats, use foot straps on both feet with a minimum of one megohm resistance between the operator and ground. To be effective, the conductive strips must be worn in contact with the skin.

The following grounding equipment is recommended to prevent electrostatic damage:

- Antistatic tape
- Antistatic smocks, aprons, and sleeve protectors
- Conductive bins and other assembly or soldering aids
- Nonconductive foam
- Conductive tabletop workstations with ground cords of one megohm resistance
- Static-dissipative tables or floor mats with hard ties to the ground
- Field service kits
- Static awareness labels
- Material-handling packages
- Nonconductive plastic bags, tubes, or boxes
- Metal tote boxes
- Electrostatic voltage levels and protective materials

The following table lists the shielding protection provided by antistatic bags and floor mats.

Material	Use	Voltage protection level
Antistatic plastic	Bags	1,500 V
Carbon-loaded plastic	Floor mats	7,500 V
Metallized laminate	Floor mats	5,000 V

## Service tag

When ordering parts or requesting information, provide the computer serial number and model number provided on the service tag.



The battery must be removed to gain access to the service tag. See the “Battery” section in Chapter 4 (“Removal and replacement procedures”) for battery removal and replacement instructions.

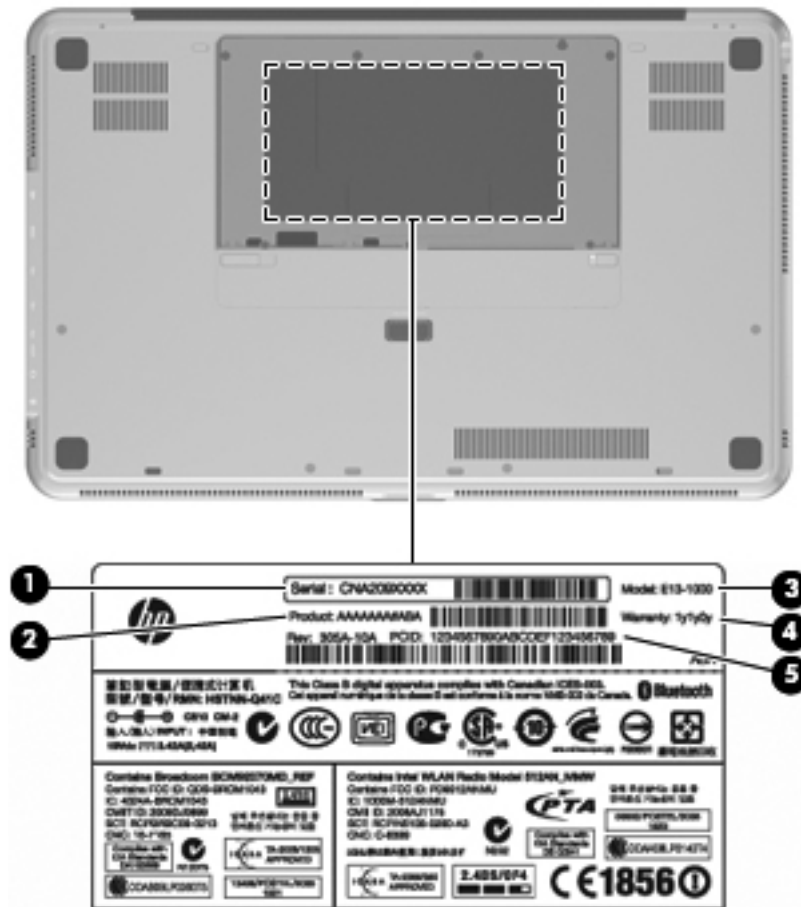

Item	Component	Description
(1)	Serial number (s/n)	This is an alphanumeric identifier that is unique to each product.
(2)	Product name	This is the product name affixed to the front of the computer.
(3)	Model description	This is the alphanumeric identifier used to locate documents, drivers, and support for the computer.
(4)	Warranty period	This number describes the duration (in years) of the warranty period for the computer.
(5)	Part number/Product number (p/n)	This number provides specific information about the product's hardware components. The part number helps a service technician determine what components and parts are needed.

## Component replacement procedures

This chapter provides removal and replacement procedures.

There are as many as 113 screws, in 9 different sizes, that must be removed, replaced, or loosened when servicing the computer. Make special note of each screw size and location during removal and replacement.

### Computer feet

The computer feet are adhesive-backed rubber pads. The feet are included in the Rubber Feet Kit, spare part number 538346-001. There are 4 rubber feet that attach to the base enclosure and battery in the locations shown in the following illustration.

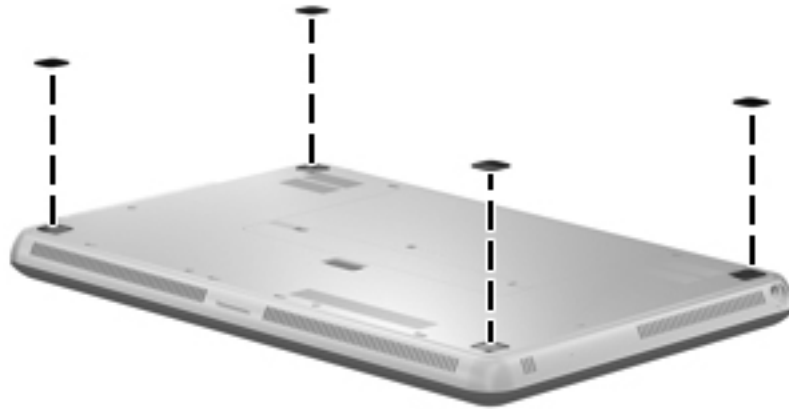

## Battery

Description	Spare part number
9-cell, 2.80-Ah (93-Wh) Li-ion battery	576834-001
6-cell, 2.40-Ah (53-Wh) Li-ion battery	576833-001 and 586025-001

Before removing the battery, follow these steps:

1. Shut down the computer.
2. Disconnect all external devices connected to the computer.
3. Disconnect the power from the computer by first unplugging the power cord from the AC outlet, and then unplugging the AC adapter from the computer.

Remove the battery:

1. Close the display and turn the computer upside down on a flat surface.
2. Slide the battery lock ❶ to unlock the battery.
3. Slide the battery release latch ❷ to release the battery.

 The battery release latch automatically returns to its original position.

4. Raise the battery and remove it from the battery bay ❸.

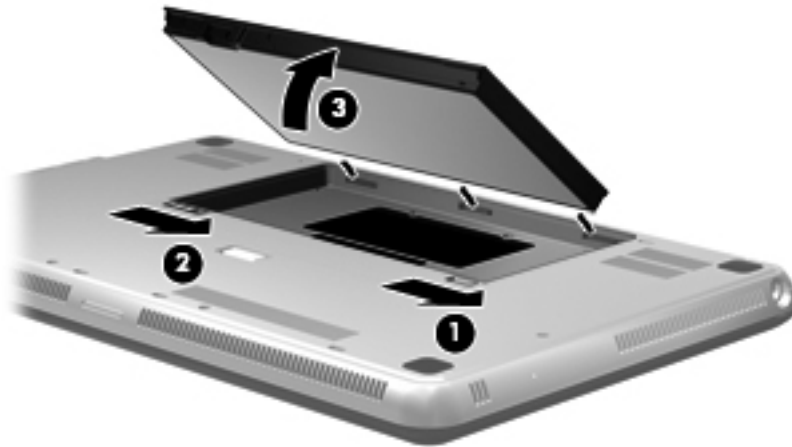

Install the battery by aligning the tabs on the battery with the notches on the outer edge of the battery bay, and then lowering the battery into the battery bay until it is seated. Slide the battery lock to lock the battery into place.

## Expansion memory module

Description	Spare part number
4096-MB memory module (1066-MHz, PC3)	576817-001
2048-MB memory module (1066-MHz, PC3)	576816-001

Before removing the expansion memory module, follow these steps:

1. Shut down the computer.
2. Disconnect all external devices connected to the computer.
3. Disconnect the power from the computer by first unplugging the power cord from the AC outlet, and then unplugging the AC adapter from the computer.
4. Remove the battery (see “[Battery](#)” on page 4-7).

Remove the expansion memory module:

1. Remove the three Phillips PM2.0×4.0 screws ❶ that secure the memory module compartment cover to the computer.
2. Lift the rear edge of the memory module compartment cover ❷ until it rests at an angle.
3. Remove the memory module compartment ❸. The memory module compartment is included in the Plastics Kit, spare part number 576847-001.

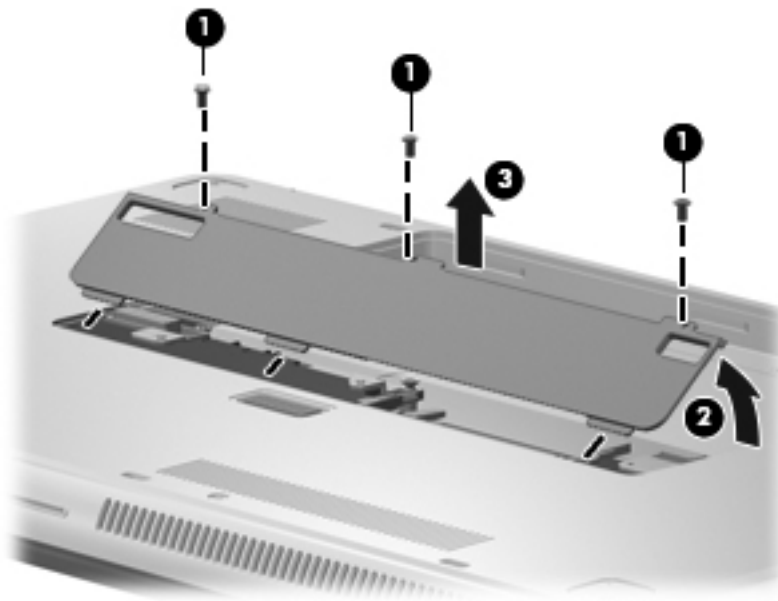

4. Pull away the retention clips ❶ on each side of the memory module to release the memory module. (The memory module tilts up.)



**CAUTION:** To prevent damage to the memory module, hold it by the edges only. Do not touch the components on the memory module.

5. Grasp the edge of the memory module ❷, and gently pull it out of the memory module slot.

 Memory modules are designed with a notch ❸ to prevent incorrect insertion into the memory module slot.

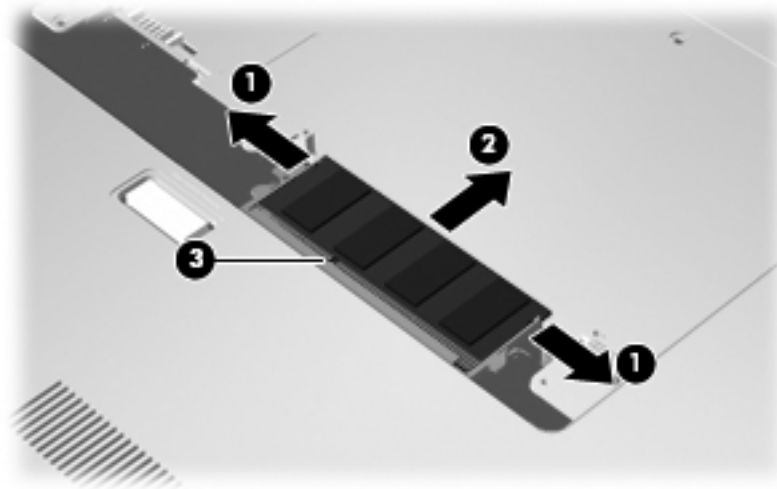

Reverse this procedure to install the expansion memory module.

## Top cover



The top cover spare part kit includes a TouchPad board, TouchPad bracket, and TouchPad cable.

Description	Spare part number
Top cover with bronze finish for use in all countries and regions except Brazil and the United Kingdom	576840-001
Top cover with bronze finish for use only in Brazil	576840-201
Top cover with bronze finish for use only in the United Kingdom	576840-031
Top cover with black finish for use in all countries and regions except the United Kingdom	580122-001
Top cover with black finish for use only in the United Kingdom	580122-031

Before removing the top cover, follow these steps:

1. Shut down the computer.
2. Disconnect all external devices connected to the computer.
3. Disconnect the power from the computer by first unplugging the power cord from the AC outlet, and then unplugging the AC adapter from the computer.
4. Remove the battery (see [“Battery” on page 4-7](#)).
5. Remove the memory module compartment cover (see [“Expansion memory module” on page 4-8](#)).

Remove the top cover:

1. Remove the four rubber feet **1** and the eight Phillips PM2.0×12.0 screws **2** that secure the top cover to the base enclosure.

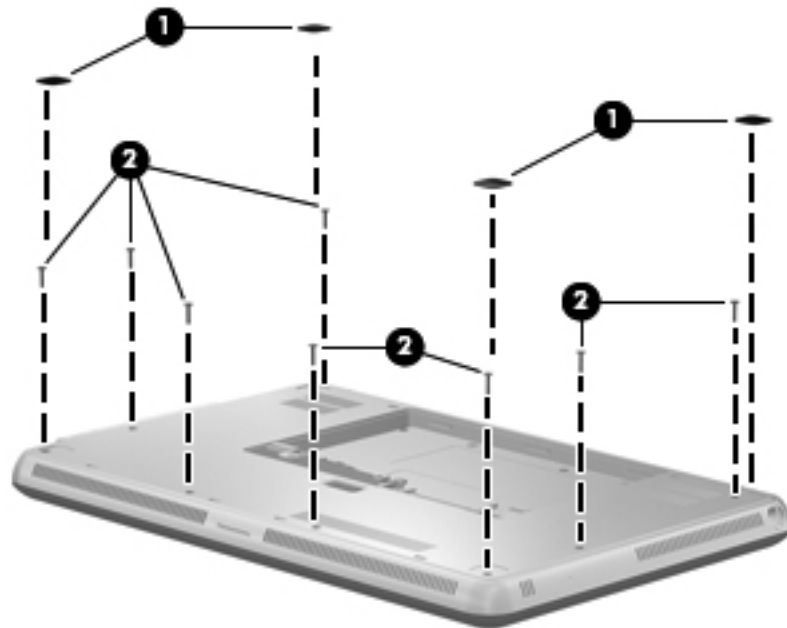



2. Remove the two Phillips PM2.0×5.0 screws ❶ and the four Phillips PM2.0×2.0 screws ❷ that secure the top cover to the base enclosure.

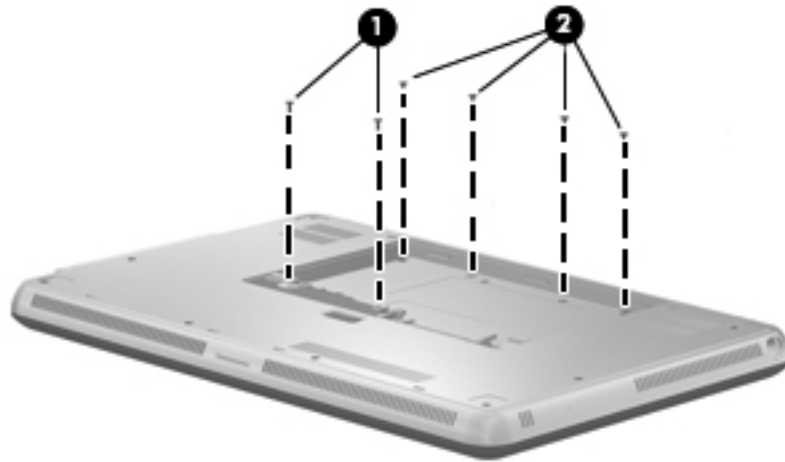

3. Turn the computer right-side up, with the front toward you.
4. Release the top cover by lifting the front edge ❶ until it rests at an angle.
5. Disconnect the LED board cable ❷ from the system board.
6. Disconnect the TouchPad cable ❸ from the low insertion force (LIF) connector on the system board.
7. Release the zero insertion force (ZIF) connector to which the keyboard cable is attached, and then disconnect the keyboard cable ❹ from the system board.
8. Remove the top cover ❺.

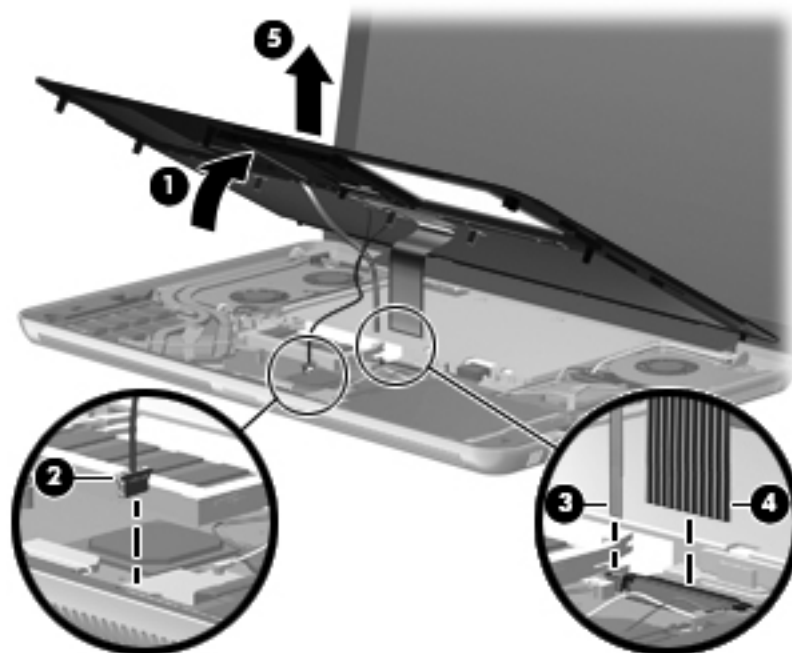

Reverse this procedure to install the top cover.

## Keyboard



The keyboard spare part kit includes a keyboard cable.

Keyboard for use in country or region	Spare part number	Keyboard for use in country or region	Spare part number
<b>With bronze finish:</b>			
Belgium	576835-A41	The Netherlands	576835-B31
Brazil	576835-201	Russia	576835-251
Denmark, Finland, and Norway	576835-DH1	Saudi Arabia	576835-171
France	576835-051	South Korea	576835-AD1
French Canada	576835-121	Spain	576835-071
Germany	576835-041	Switzerland	576835-BG1
Italy	576835-061	The United Kingdom and Singapore	576835-031
Latin America	576835-161	The United States	576835-001
<b>With black finish:</b>			
France	580132-051	The United Kingdom and Singapore	580132-031
Saudi Arabia	580132-171	The United States	580132-001
Keyboard Hardware Kit (includes Mylar shield and screws)			576836-001

Before removing the keyboard, follow these steps:

1. Shut down the computer.
2. Disconnect all external devices connected to the computer.
3. Disconnect the power from the computer by first unplugging the power cord from the AC outlet, and then unplugging the AC adapter from the computer.
4. Remove the battery (see [“Battery” on page 4-7](#)).
5. Remove the memory module compartment cover (see [“Expansion memory module” on page 4-8](#)).
6. Remove the top cover (see [“Top cover” on page 4-10](#)).

Remove the keyboard:

1. Turn the top cover upside down, with the front toward you.
2. Remove the Mylar shield from the back of the keyboard. The Mylar shield is available in the Keyboard Hardware Kit, spare part number 576836-001.

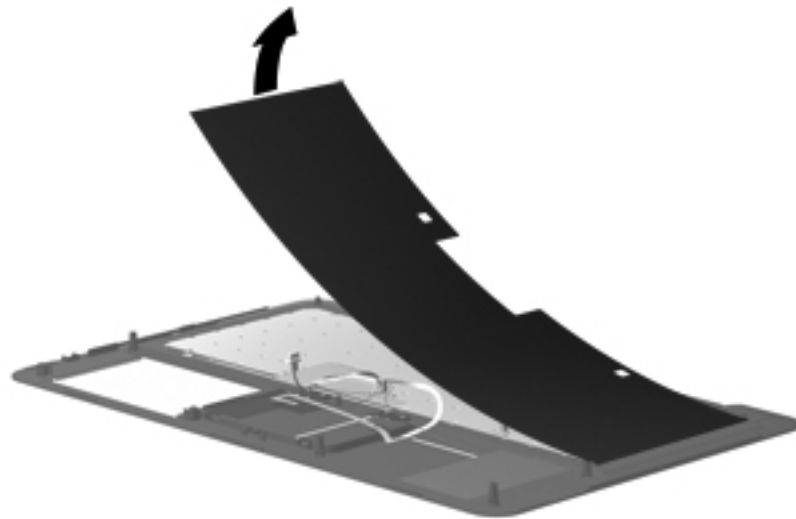

3. Remove the 60 Phillips PM1.5×1.5 screws that secure the keyboard to the top cover.

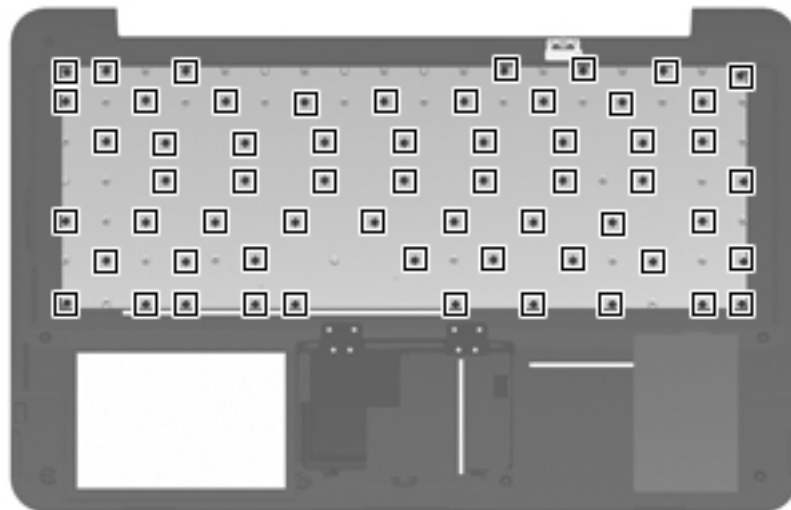

4. Remove the keyboard.

Reverse this procedure to install the keyboard.

## Speaker assembly

Description	Spare part number
Speaker assembly	576842-001

Before removing the speaker assembly, follow these steps:

1. Shut down the computer.
2. Disconnect all external devices connected to the computer.
3. Disconnect the power from the computer by first unplugging the power cord from the AC outlet, and then unplugging the AC adapter from the computer.
4. Remove the battery (see [“Battery” on page 4-7](#)).
5. Remove the memory module compartment cover (see [“Expansion memory module” on page 4-8](#)).
6. Remove the top cover (see [“Top cover” on page 4-10](#)).

Remove the speaker assembly:

1. Disconnect the speaker assembly cable ❶ from the system board.
2. Remove the two Phillips PM2.0×4.0 screws ❷ that secure the speaker assembly to the base enclosure.
3. Remove the speaker assembly ❸.

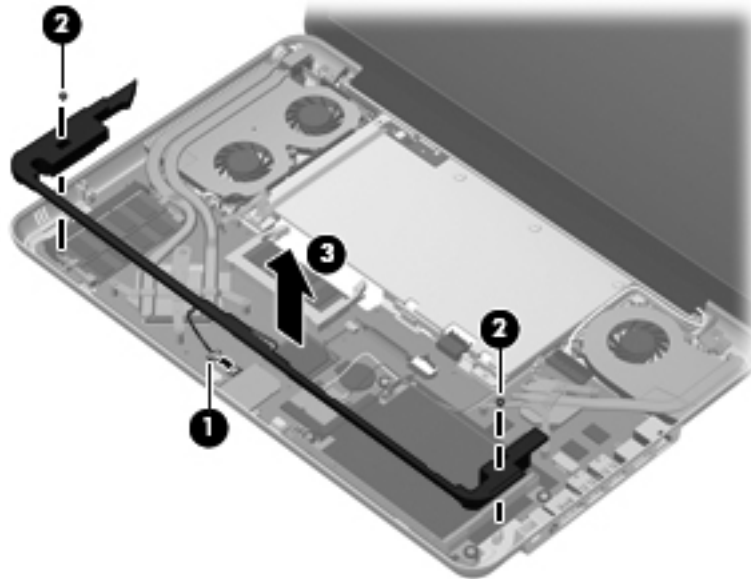

Reverse this procedure to install the speaker assembly.

## Primary memory module

Description	Spare part number
4096-MB memory module (1066-MHz, PC3)	576817-001
2048-MB memory module (1066-MHz, PC3)	576816-001

Before removing the primary memory module, follow these steps:

1. Shut down the computer.
2. Disconnect all external devices connected to the computer.
3. Disconnect the power from the computer by first unplugging the power cord from the AC outlet, and then unplugging the AC adapter from the computer.
4. Remove the battery (see [“Battery” on page 4-7](#)).
5. Remove the memory module compartment cover (see [“Expansion memory module” on page 4-8](#)).
6. Remove the top cover (see [“Top cover” on page 4-10](#)).

Remove the primary memory module:

1. Pull away the retention clips ❶ on each side of the memory module to release the memory module. (The memory module tilts up.)



**CAUTION:** To prevent damage to the memory module, hold it by the edges only. Do not touch the components on the memory module.

2. Grasp the edge of the memory module ❷, and gently pull it out of the memory module slot.

 Memory modules are designed with a notch ❸ to prevent incorrect insertion into the memory module slot.

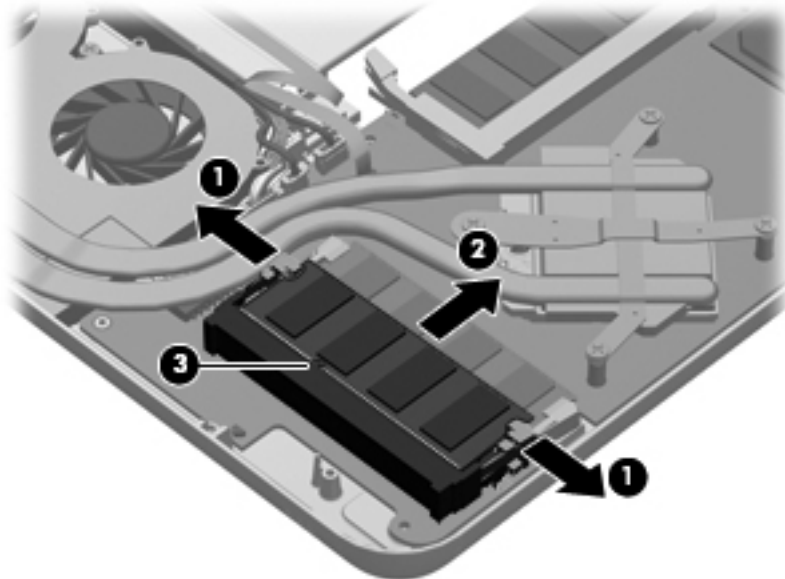

Reverse this procedure to install the primary memory module.

## WLAN module

Description	Spare part number
Intel WiFi Link 6200 802.11 a/g/n WLAN module for use in Andorra, Antigua and Barbuda, Argentina, Aruba, Australia, Austria, Azerbaijan, Bahamas, Bahrain, Barbados, Belgium, Bermuda, Bolivia, Bosnia, Brazil, Brunei, Bulgaria, Canada, the Cayman Islands, Chile, Colombia, Costa Rica, Croatia, Cyprus, the Czech Republic, Denmark, the Dominican Republic, Ecuador, Egypt, El Salvador, Estonia, Finland, France, French Guiana, Georgia, Germany, Ghana, Greece, Guadeloupe, Guam, Guatemala, Haiti, Herzegovina, Honduras, Hong Kong, Hungary, Iceland, India, Indonesia, Ireland, Israel, Italy, the Ivory Coast, Jamaica, Japan, Jordan, Kenya, Kuwait, Kyrgyzstan, Latvia, Lebanon, Liechtenstein, Lithuania, Luxembourg, Malawi, Malaysia, Malta, Martinique, Mauritius, Mexico, Monaco, Montenegro, Morocco, the Nether Antilles, the Netherlands, New Zealand, Nicaragua, Nigeria, Norway, Oman, Panama, Paraguay, the People's Republic China, Peru, the Philippines, Poland, Portugal, Puerto Rico, Qatar, Romania, San Marino, Saudi Arabia, Senegal, Serbia, Singapore, Slovakia, Slovenia, South Africa, South Korea, Spain, Sweden, Switzerland, Taiwan, Tanzania, Thailand, Trinidad and Tobago, Turkey, the United Arab Emirates, the United Kingdom, Uruguay, the U.S. Virgin Islands, the United States, Venezuela, and Vietnam	572509-001
Intel WiFi Link 5100 802.11 a/g/n WLAN module for use in Andorra, Antigua and Barbuda, Argentina, Aruba, Australia, Austria, Azerbaijan, Bahamas, Bahrain, Barbados, Belgium, Bermuda, Bolivia, Bosnia, Brazil, Brunei, Bulgaria, Canada, the Cayman Islands, Chile, Colombia, Costa Rica, Croatia, Cyprus, the Czech Republic, Denmark, the Dominican Republic, Ecuador, Egypt, El Salvador, Estonia, Finland, France, French Guiana, Georgia, Germany, Ghana, Greece, Guadeloupe, Guam, Guatemala, Haiti, Herzegovina, Honduras, Hong Kong, Hungary, Iceland, India, Indonesia, Ireland, Israel, Italy, the Ivory Coast, Jamaica, Japan, Jordan, Kenya, Kuwait, Kyrgyzstan, Latvia, Lebanon, Liechtenstein, Lithuania, Luxembourg, Malawi, Malaysia, Malta, Martinique, Mauritius, Mexico, Monaco, Montenegro, Morocco, the Nether Antilles, the Netherlands, New Zealand, Nicaragua, Nigeria, Norway, Oman, Panama, Paraguay, the People's Republic China, Peru, the Philippines, Poland, Portugal, Puerto Rico, Qatar, Romania, San Marino, Saudi Arabia, Senegal, Serbia, Singapore, Slovakia, Slovenia, South Africa, South Korea, Spain, Sweden, Switzerland, Taiwan, Tanzania, Thailand, Trinidad and Tobago, Turkey, the United Arab Emirates, the United Kingdom, Uruguay, the U.S. Virgin Islands, the United States, Venezuela, and Vietnam	572507-001
Intel WiFi Link 6100 802.11 a/b/g WLAN module for use in Andorra, Antigua and Barbuda, Argentina, Aruba, Australia, Austria, Azerbaijan, Bahamas, Bahrain, Barbados, Belgium, Bermuda, Bolivia, Bosnia, Brazil, Brunei, Bulgaria, Canada, the Cayman Islands, Chile, Colombia, Costa Rica, Croatia, Cyprus, the Czech Republic, Denmark, the Dominican Republic, Ecuador, Egypt, El Salvador, Estonia, Finland, France, French Guiana, Georgia, Germany, Ghana, Greece, Guadeloupe, Guam, Guatemala, Haiti, Herzegovina, Honduras, Hong Kong, Hungary, Iceland, India, Indonesia, Ireland, Israel, Italy, the Ivory Coast, Jamaica, Japan, Jordan, Kenya, Kuwait, Kyrgyzstan, Latvia, Lebanon, Liechtenstein, Lithuania, Luxembourg, Malawi, Malaysia, Malta, Martinique, Mauritius, Mexico, Monaco, Montenegro, Morocco, the Nether Antilles, the Netherlands, New Zealand, Nicaragua, Nigeria, Norway, Oman, Panama, Paraguay, the People's Republic China, Peru, the Philippines, Poland, Portugal, Puerto Rico, Qatar, Romania, San Marino, Saudi Arabia, Senegal, Serbia, Singapore, Slovakia, Slovenia, South Africa, South Korea, Spain, Sweden, Switzerland, Taiwan, Tanzania, Thailand, Trinidad and Tobago, Turkey, the United Arab Emirates, the United Kingdom, Uruguay, the U.S. Virgin Islands, the United States, Venezuela, and Vietnam	572510-001

(Continued)



Description	Spare part number
Intel WiFi Link 5100 802.11 a/b/g WLAN module for use in Andorra, Antigua and Barbuda, Argentina, Aruba, Australia, Austria, Azerbaijan, Bahamas, Bahrain, Barbados, Belgium, Bermuda, Bolivia, Bosnia, Brazil, Brunei, Bulgaria, Canada, the Cayman Islands, Chile, Colombia, Costa Rica, Croatia, Cyprus, the Czech Republic, Denmark, the Dominican Republic, Ecuador, Egypt, El Salvador, Estonia, Finland, France, French Guiana, Georgia, Germany, Ghana, Greece, Guadeloupe, Guam, Guatemala, Haiti, Herzegovina, Honduras, Hong Kong, Hungary, Iceland, India, Indonesia, Ireland, Israel, Italy, the Ivory Coast, Jamaica, Japan, Jordan, Kenya, Kuwait, Kyrgyzstan, Latvia, Lebanon, Liechtenstein, Lithuania, Luxembourg, Malawi, Malaysia, Malta, Martinique, Mauritius, Mexico, Monaco, Montenegro, Morocco, the Nether Antilles, the Netherlands, New Zealand, Nicaragua, Nigeria, Norway, Oman, Panama, Paraguay, the People's Republic China, Peru, the Philippines, Poland, Portugal, Puerto Rico, Qatar, Romania, San Marino, Saudi Arabia, Senegal, Serbia, Singapore, Slovakia, Slovenia, South Africa, South Korea, Spain, Sweden, Switzerland, Taiwan, Tanzania, Thailand, Trinidad and Tobago, Turkey, the United Arab Emirates, the United Kingdom, Uruguay, the U.S. Virgin Islands, the United States, Venezuela, and Vietnam	572508-001
Intel 1000 802.11 b/g/n WLAN module for use in Andorra, Antigua and Barbuda, Argentina, Aruba, Australia, Austria, Azerbaijan, Bahamas, Bahrain, Barbados, Belgium, Bermuda, Bolivia, Bosnia, Brazil, Brunei, Bulgaria, Canada, the Cayman Islands, Chile, Colombia, Costa Rica, Croatia, Cyprus, the Czech Republic, Denmark, the Dominican Republic, Ecuador, Egypt, El Salvador, Estonia, Finland, France, French Guiana, Georgia, Germany, Ghana, Greece, Guadeloupe, Guam, Guatemala, Haiti, Herzegovina, Honduras, Hong Kong, Hungary, Iceland, India, Indonesia, Ireland, Israel, Italy, the Ivory Coast, Jamaica, Japan, Jordan, Kenya, Kuwait, Kyrgyzstan, Latvia, Lebanon, Liechtenstein, Lithuania, Luxembourg, Malawi, Malaysia, Malta, Martinique, Mauritius, Mexico, Monaco, Montenegro, Morocco, the Nether Antilles, the Netherlands, New Zealand, Nicaragua, Nigeria, Norway, Oman, Panama, Paraguay, the People's Republic China, Peru, the Philippines, Poland, Portugal, Puerto Rico, Qatar, Romania, San Marino, Saudi Arabia, Senegal, Serbia, Singapore, Slovakia, Slovenia, South Africa, South Korea, Spain, Sweden, Switzerland, Taiwan, Tanzania, Thailand, Trinidad and Tobago, Turkey, the United Arab Emirates, the United Kingdom, Uruguay, the U.S. Virgin Islands, the United States, Venezuela, and Vietnam	572520-001
Intel 1000 802.11 b/g WLAN module for use in Andorra, Antigua and Barbuda, Argentina, Aruba, Australia, Austria, Azerbaijan, Bahamas, Bahrain, Barbados, Belgium, Bermuda, Bolivia, Bosnia, Brazil, Brunei, Bulgaria, Canada, the Cayman Islands, Chile, Colombia, Costa Rica, Croatia, Cyprus, the Czech Republic, Denmark, the Dominican Republic, Ecuador, Egypt, El Salvador, Estonia, Finland, France, French Guiana, Georgia, Germany, Ghana, Greece, Guadeloupe, Guam, Guatemala, Haiti, Herzegovina, Honduras, Hong Kong, Hungary, Iceland, India, Indonesia, Ireland, Israel, Italy, the Ivory Coast, Jamaica, Japan, Jordan, Kenya, Kuwait, Kyrgyzstan, Latvia, Lebanon, Liechtenstein, Lithuania, Luxembourg, Malawi, Malaysia, Malta, Martinique, Mauritius, Mexico, Monaco, Montenegro, Morocco, the Nether Antilles, the Netherlands, New Zealand, Nicaragua, Nigeria, Norway, Oman, Panama, Paraguay, the People's Republic China, Peru, the Philippines, Poland, Portugal, Puerto Rico, Qatar, Romania, San Marino, Saudi Arabia, Senegal, Serbia, Singapore, Slovakia, Slovenia, South Africa, South Korea, Spain, Sweden, Switzerland, Taiwan, Tanzania, Thailand, Trinidad and Tobago, Turkey, the United Arab Emirates, the United Kingdom, Uruguay, the U.S. Virgin Islands, the United States, Venezuela, and Vietnam	585984-001

Before removing the WLAN module, follow these steps:

1. Shut down the computer.
2. Disconnect all external devices connected to the computer.
3. Disconnect the power from the computer by first unplugging the power cord from the AC outlet, and then unplugging the AC adapter from the computer.
4. Remove the battery (see [“Battery” on page 4-7](#)).
5. Remove the memory module compartment cover (see [“Expansion memory module” on page 4-8](#)).
6. Remove the top cover (see [“Top cover” on page 4-10](#)).

Remove the WLAN module:

**CAUTION:** To prevent an unresponsive system, replace the wireless module only with a wireless module authorized for use in the computer by the governmental agency that regulates wireless devices in your country or region. If you replace the module and then receive a warning message, remove the module to restore computer functionality, and then contact technical support through Help and Support.

1. Remove the wireless antenna cables from the clip **1** built into the hard drive bracket.
2. Disconnect the WLAN antenna cables **2** from the terminals on the WLAN module.
  -  The black WLAN antenna cable is connected to the WLAN module “Main” terminal. The white WLAN antenna cable is connected to the WLAN module “Aux” terminal.
3. Remove the Phillips PM2.0×4.0 screw **3** that secures the WLAN module to the system board. (The WLAN module tilts up.)
4. Remove the WLAN module **4** by pulling it away from the slot at an angle.
  -  WLAN modules are designed with a notch **5** to prevent incorrect insertion of the WLAN module into the WLAN module slot.

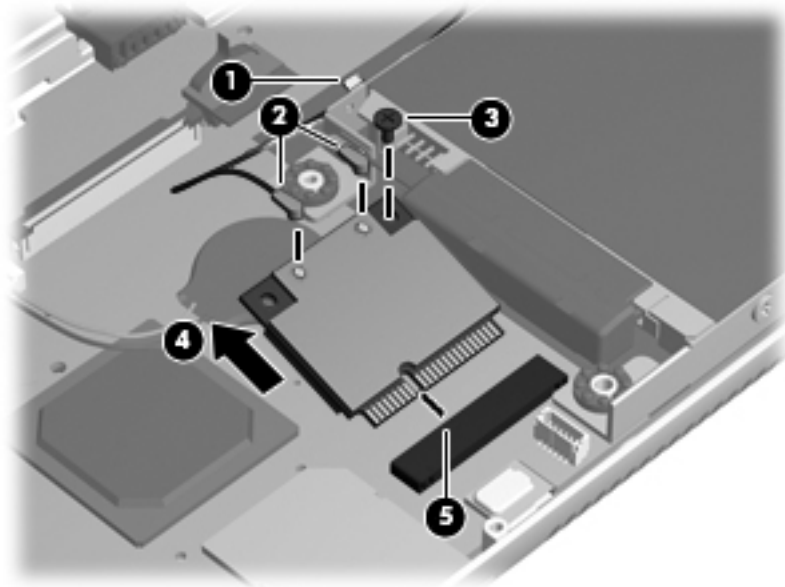

Reverse this procedure to install the WLAN module.



## RTC battery

Description	Spare part number
RTC battery (includes double-sided tape)	576848-001

Before removing the RTC battery, follow these steps:

1. Shut down the computer.
2. Disconnect all external devices connected to the computer.
3. Disconnect the power from the computer by first unplugging the power cord from the AC outlet, and then unplugging the AC adapter from the computer.
4. Remove the battery (see [“Battery” on page 4-7](#)).
5. Remove the memory module compartment cover (see [“Expansion memory module” on page 4-8](#)).
6. Remove the top cover (see [“Top cover” on page 4-10](#)).

Remove the RTC battery:

1. Disconnect the RTC battery cable ❶ from the system board.
2. Detach the RTC battery ❷ from the system board. (The RTC battery is attached to the system board with double-sided tape.)

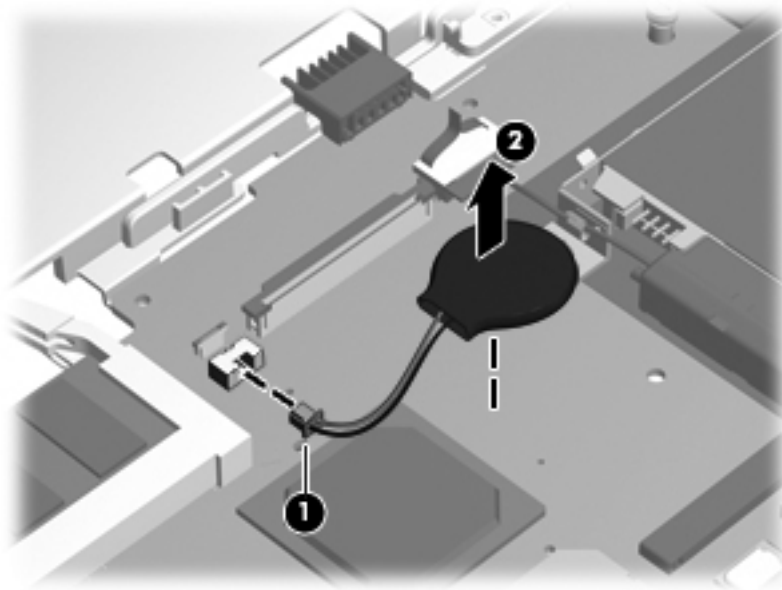

3. Remove the RTC battery.

Reverse this procedure to install the RTC battery.

## Hard drive



The hard drive spare part kit includes a hard drive bracket, rubber isolators, and screws.

Description	Spare part number
<b>2.5-in, 7200-rpm hard drive:</b>	
640-GB	576821-001
500-GB	576820-001
320-GB	576819-001
250-GB	576818-001
<b>1.8-in, 5400-rpm hard drive:</b>	
320-GB	576823-001
250-GB	580129-001
160-GB	591171-001
<b>Hard drive cable:</b>	
For use only with 2.5-in hard drives	576828-001
For use only with 1.8-in hard drives	576830-001
<b>Hard Drive Hardware Kit (includes bracket, rubber isolators, and screws):</b>	
For use only with 2.5-in hard drives	576827-001
For use only with 1.8-in hard drives	576829-001

Before removing the hard drive, follow these steps:

1. Shut down the computer.
2. Disconnect all external devices connected to the computer.
3. Disconnect the power from the computer by first unplugging the power cord from the AC outlet, and then unplugging the AC adapter from the computer.
4. Remove the battery (see [“Battery” on page 4-7](#)).
5. Remove the memory module compartment cover (see [“Expansion memory module” on page 4-8](#)).
6. Remove the top cover (see [“Top cover” on page 4-10](#)).

Remove the hard drive:

1. Disconnect the hard drive cable ❶ from the system board.
2. Remove the two Phillips PM2.0×4.0 broadhead screws ❷ that secure the hard drive to the base enclosure.
3. Remove the hard drive ❸.

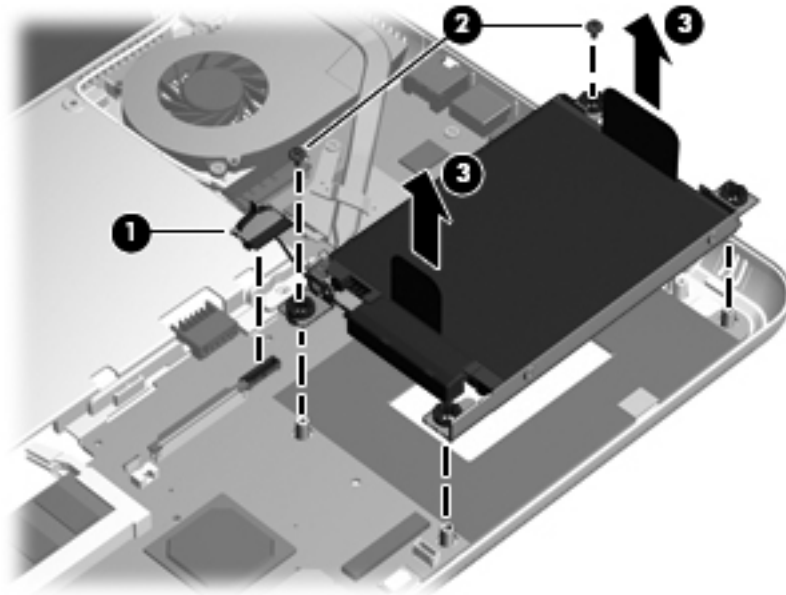

4. If it is necessary to replace the hard drive cable or bracket:
  - a. Disconnect the hard drive cable ❶ from the hard drive.
  - b. Remove the four Phillips PM3.0×4.0 screws ❷ that secure the hard drive bracket to the hard drive.
  - c. Remove the hard drive bracket ❸.

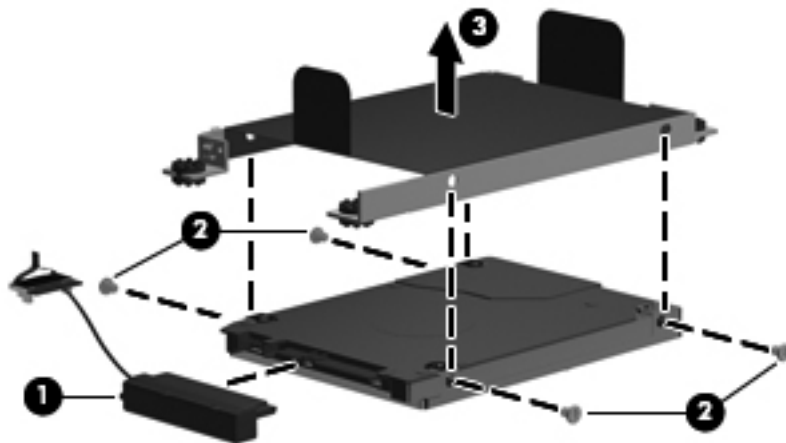

Reverse this procedure to reassemble and install the hard drive.

## Processor fan/heat sink assembly

Description	Spare part number
Processor fan/heat sink assembly (includes replacement thermal material)	576837-001

Before removing the processor fan/heat sink assembly, follow these steps:

1. Shut down the computer.
2. Disconnect all external devices connected to the computer.
3. Disconnect the power from the computer by first unplugging the power cord from the AC outlet, and then unplugging the AC adapter from the computer.
4. Remove the battery (see [“Battery” on page 4-7](#)).
5. Remove the memory module compartment cover (see [“Expansion memory module” on page 4-8](#)).
6. Remove the top cover (see [“Top cover” on page 4-10](#)).

Remove the processor fan/heat sink assembly:

1. Disconnect the fan cable ❶ from the system board.
2. Following the 1, 2, 3, 4 sequence stamped into the processor fan/heat sink assembly, loosen the four Phillips PM2.0×6.0 captive screws ❷ that secure the processor fan/heat sink assembly to the system board.
3. Remove the Phillips PM2.0×3.0 screw ❸ that secures the processor fan/heat sink assembly to the system board.
4. Remove the processor fan/heat sink assembly ❹.

 Due to the adhesive quality of the thermal material located between the processor fan/heat sink assembly and system board components, it may be necessary to move the processor fan/heat sink assembly from side to side to detach it.

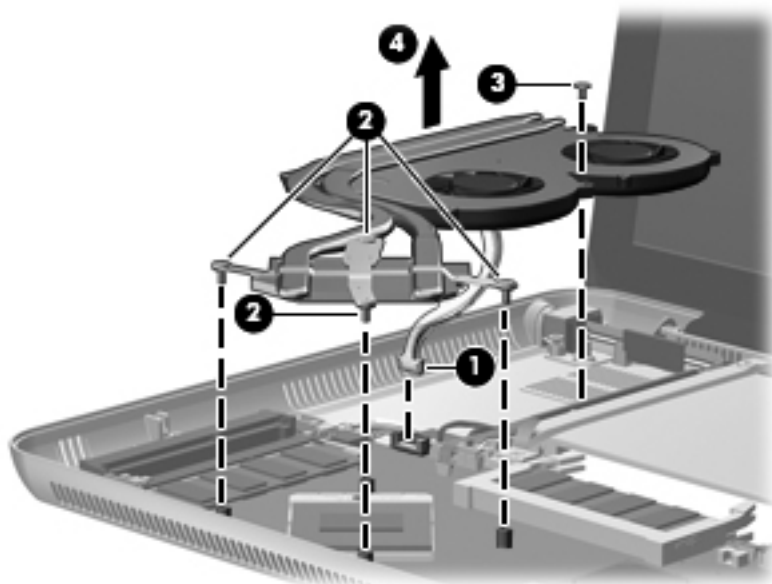



The thermal material must be thoroughly cleaned from the surfaces of the processor fan/heat sink assembly and the system board each time the processor fan/heat sink assembly is removed. Thermal paste is used on the processor ❶ and the processor fan/heat sink assembly section ❷ that services it. Replacement thermal material is included with all system board, processor, and fan/heat sink assembly spare part kits.

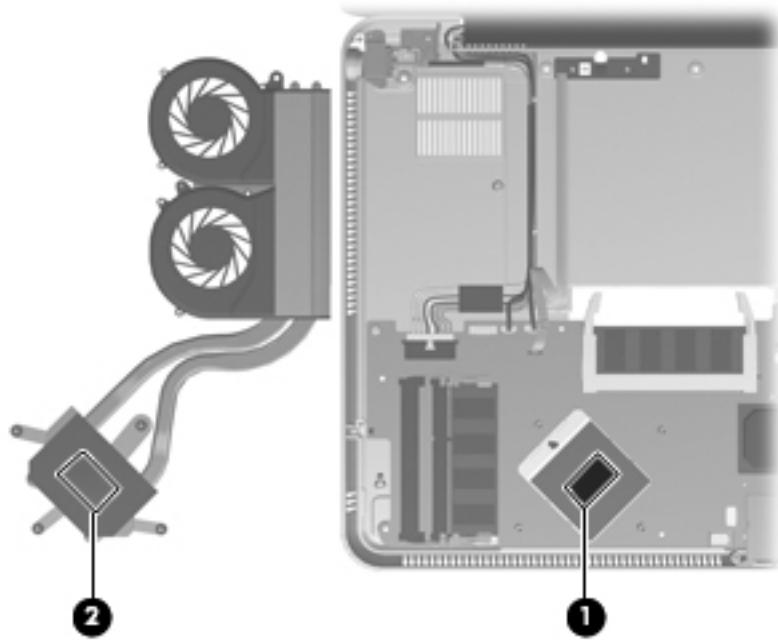

Reverse this procedure to install the processor fan/heat sink assembly.

## Processor



The processor spare part kit includes replacement thermal material.

Description	Spare part number
Intel Core i7-820QM 1.73-GHz processor (SC turbo up to 3.06-GHz)	583053-001
Intel Core i7-720QM 1.60-GHz processor (SC turbo up to 2.80-GHz)	586170-001

Before removing the processor, follow these steps:

1. Shut down the computer. If you are unsure whether the computer is off or in Hibernation, turn the computer on, and then shut it down through the operating system.
2. Disconnect all external devices connected to the computer.
3. Disconnect the power from the computer by first unplugging the power cord from the AC outlet and then unplugging the AC adapter from the computer.
4. Remove the battery (see [“Battery” on page 4-7](#)).
5. Remove the following components:
  - a. Memory module compartment cover (see [“Expansion memory module” on page 4-8](#))
  - b. Top cover (see [“Top cover” on page 4-10](#))
  - c. Processor fan/heat sink assembly (see [“Processor fan/heat sink assembly” on page 4-22](#))

Remove the processor:

1. Turn the processor locking screw ❶ one-half turn counterclockwise, until you hear a click.
2. Lift the processor ❷ straight up and remove it.



The gold triangle ❸ on the processor must be aligned with the triangle icon ❹ embossed on the processor socket when you install the processor.

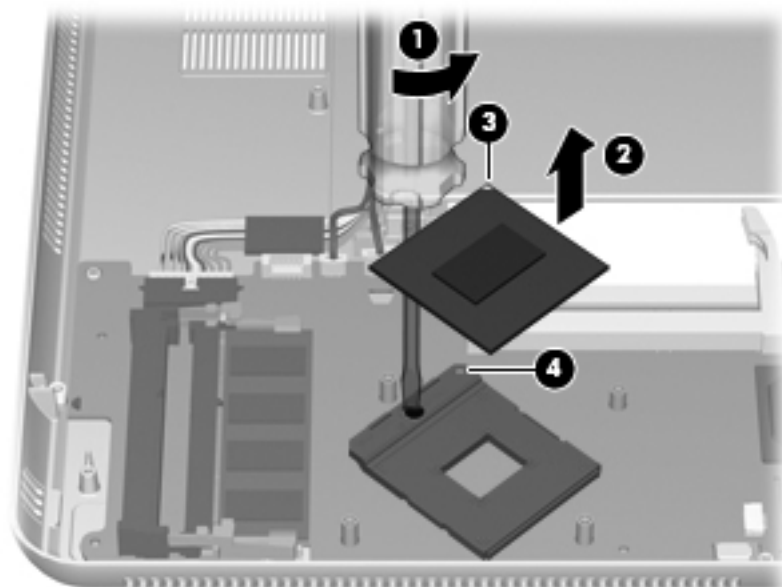

Reverse this procedure to install the processor.

## Power button board and cable

Description	Spare part number
Power button board and cable (includes double-sided tape)	576849-001

Before removing the power button board and cable, follow these steps:

1. Shut down the computer.
2. Disconnect all external devices connected to the computer.
3. Disconnect the power from the computer by first unplugging the power cord from the AC outlet, and then unplugging the AC adapter from the computer.
4. Remove the battery (see [“Battery” on page 4-7](#)).
5. Remove the following components:
  - a. Memory module compartment cover (see [“Expansion memory module” on page 4-8](#))
  - b. Top cover (see [“Top cover” on page 4-10](#))
  - c. Processor fan/heat sink assembly (see [“Processor fan/heat sink assembly” on page 4-22](#))

Remove the power button board and cable:

1. Disconnect the power button board cable ❶ from the LIF connector on the system board.
2. Detach the power button board cable ❷ and power button board ❸ from the base enclosure. (The power button board cable and power button board are attached to the base enclosure with double-sided tape.)

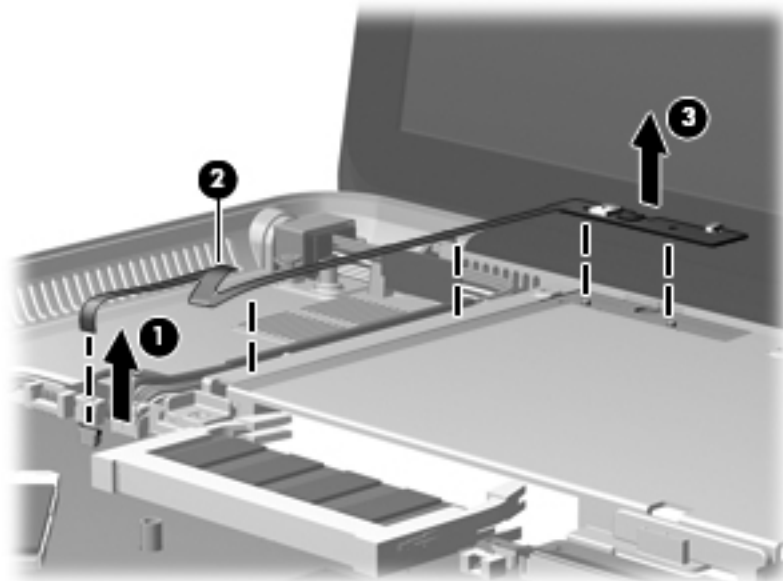

3. Remove the power button board and cable.

Reverse this procedure to install the power button board and cable.

## Power connector cable

Description	Spare part number
Power connector cable (includes bracket)	576846-001

Before removing the power connector cable, follow these steps:

1. Shut down the computer.
2. Disconnect all external devices connected to the computer.
3. Disconnect the power from the computer by first unplugging the power cord from the AC outlet, and then unplugging the AC adapter from the computer.
4. Remove the battery (see [“Battery” on page 4-7](#)).
5. Remove the following components:
  - a. Memory module compartment cover (see [“Expansion memory module” on page 4-8](#))
  - b. Top cover (see [“Top cover” on page 4-10](#))
  - c. Processor fan/heat sink assembly (see [“Processor fan/heat sink assembly” on page 4-22](#))

Remove the power connector cable:

1. Disconnect the power connector cable ❶ from the system board.
2. Remove the two Phillips PM2.0×3.0 screws ❷ that secure the power connector bracket and power connector to the base enclosure.
3. Remove the power connector bracket ❸.
4. Remove the power connector cable ❹ from the base enclosure.

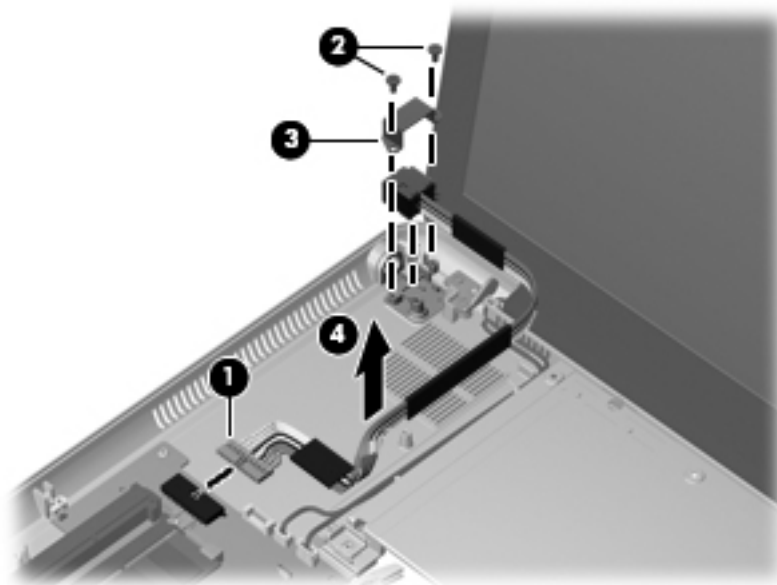

Reverse this procedure to install the power connector cable.



## Video fan/heat sink assembly

Description	Spare part number
Video fan/heat sink assembly (includes replacement thermal material)	576838-001

Before removing the video fan/heat sink assembly, follow these steps:

1. Shut down the computer.
2. Disconnect all external devices connected to the computer.
3. Disconnect the power from the computer by first unplugging the power cord from the AC outlet, and then unplugging the AC adapter from the computer.
4. Remove the battery (see [“Battery” on page 4-7](#)).
5. Remove the memory module compartment cover (see [“Expansion memory module” on page 4-8](#)).
6. Remove the top cover (see [“Top cover” on page 4-10](#)).

Remove the video fan/heat sink assembly:

1. Disconnect the fan cable ❶ from the system board.
2. Following the 1, 2, 3 sequence stamped into the video fan/heat sink assembly, loosen the three Phillips PM2.0×6.0 captive screws ❷ that secure the video fan/heat sink assembly to the system board.
3. Remove the two Phillips PM2.0×3.0 screws ❸ that secure the video fan/heat sink assembly to the system board.
4. Remove the video fan/heat sink assembly ❹.

 Due to the adhesive quality of the thermal material located between the video fan/heat sink assembly and system board components, it may be necessary to move the video fan/heat sink assembly from side to side to detach it.

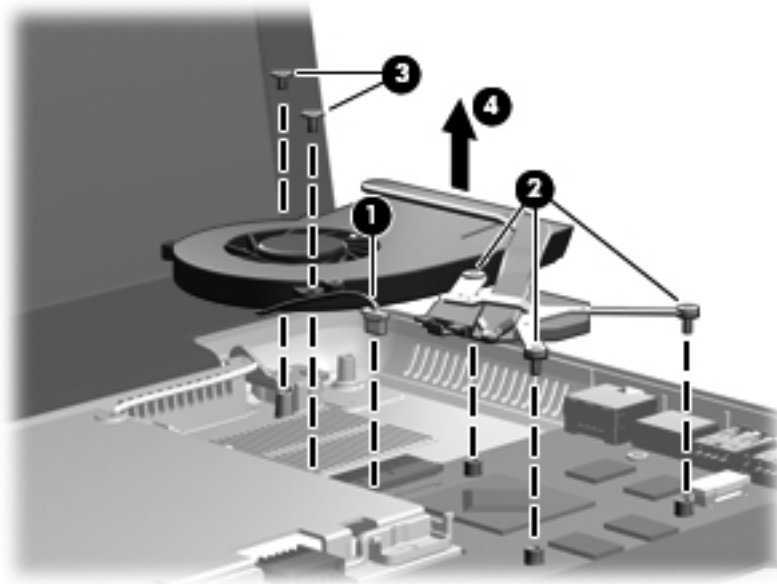



The thermal material must be thoroughly cleaned from the surfaces of the video fan/heat sink assembly and the system board each time the video fan/heat sink assembly is removed. Thermal paste is used on the video processor ❶ and the video fan/heat sink assembly section ❷ that services it. Replacement thermal material is included with all system board and fan/heat sink assembly spare part kits.

---

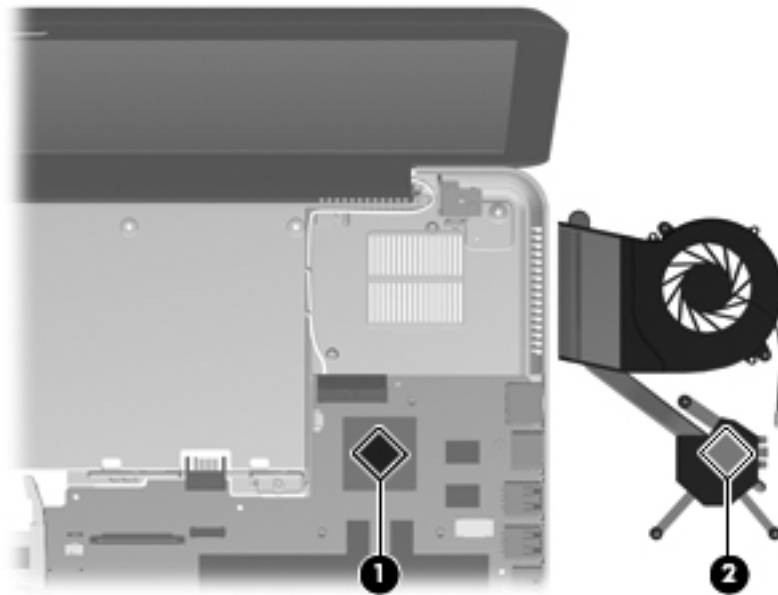

Reverse this procedure to install the video fan/heat sink assembly.

## System board

Description	Spare part number
PM57 PCH Peak-M system board with 1 GB of dedicated video memory (includes replacement thermal material)	576772-001

Before removing the system board, follow these steps:

1. Shut down the computer.
2. Disconnect all external devices connected to the computer.
3. Disconnect the power from the computer by first unplugging the power cord from the AC outlet, and then unplugging the AC adapter from the computer.
4. Remove the battery (see [“Battery” on page 4-7](#)).
5. Remove the following components:
  - a. Memory module compartment cover (see [“Expansion memory module” on page 4-8](#))
  - b. Top cover (see [“Top cover” on page 4-10](#))
  - c. Speaker assembly (see [“Speaker assembly” on page 4-14](#))
  - d. Hard drive (see [“Hard drive” on page 4-20](#))
  - e. Processor fan/heat sink assembly (see [“Processor fan/heat sink assembly” on page 4-22](#))
  - f. Video fan/heat sink assembly (see [“Video fan/heat sink assembly” on page 4-27](#))

When replacing the system board, be sure that the following additional components are removed from the defective system board and installed on the replacement system board:

- Expansion and primary memory modules (see [“Expansion memory module” on page 4-8](#) and [“Primary memory module” on page 4-15](#))
- WLAN module (see [“WLAN module” on page 4-16](#))
- RTC battery (see [“RTC battery” on page 4-19](#))
- Processor (see [“Processor” on page 4-24](#))

Remove the system board:

1. Disconnect the following cables from the system board:

- Power connector cable ❶
- Power button board cable ❷
- Bluetooth module cable ❸
- Ambient light sensor module cable ❹

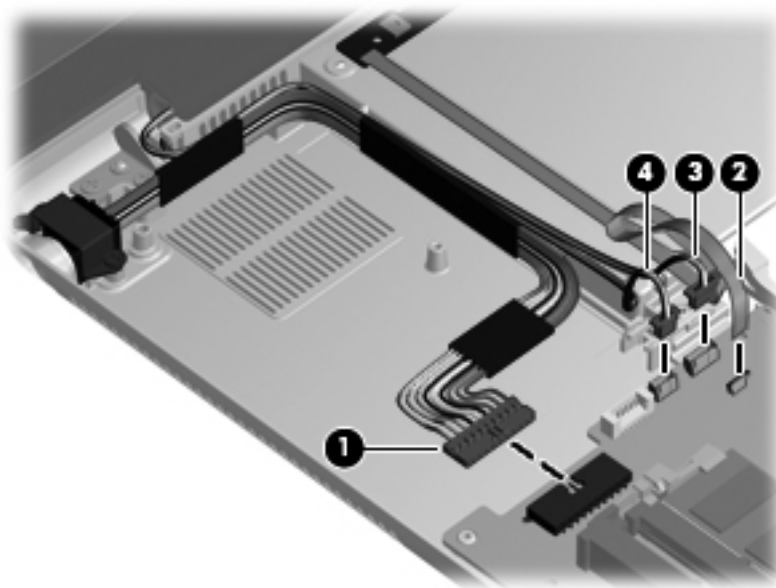

2. Disconnect the wireless antenna cables ❶ from the WLAN module.

✎ The black WLAN antenna cable is connected to the WLAN module “Main” terminal. The white WLAN antenna cable is connected to the WLAN module “Aux” terminal.

3. Disconnect the display panel cable ❷ from the system board.

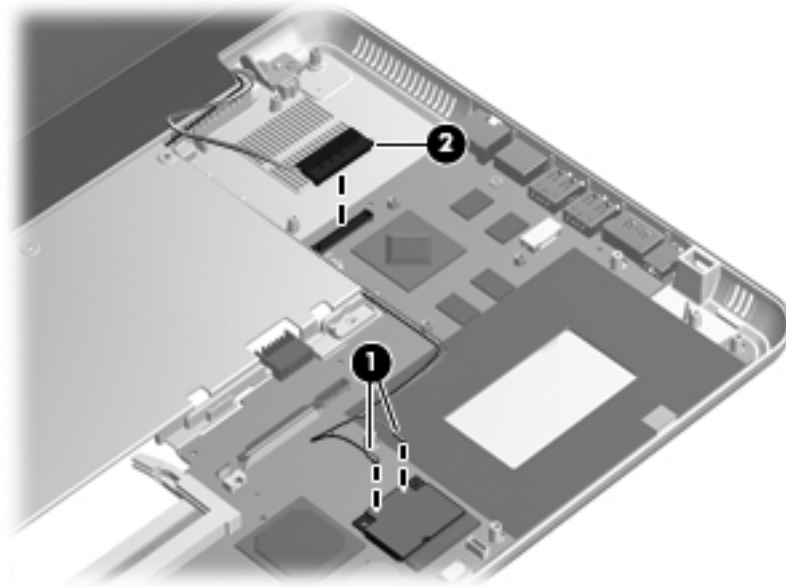

4. Remove the four Phillips PM2.0×4.0 screws ❶ that secure the system board to the base enclosure.
5. Lift the left side of the system board ❷ until it rests at an angle.
6. Remove the system board ❸ by sliding it up and to the left at an angle.

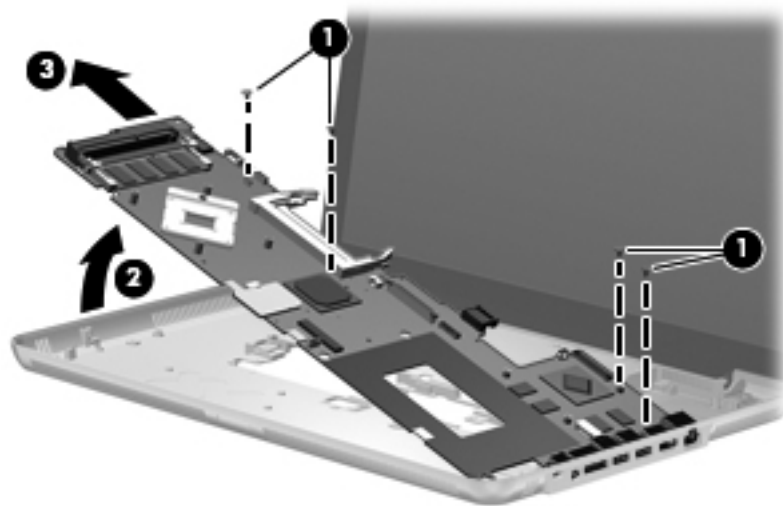

Reverse this procedure to install the system board.

## Display assembly



The display assembly spare part kit includes a webcam/microphone module and cable, 2 WLAN antenna transceivers and cables, nameplate, and logo.

Description	Spare part number
<b>With bronze finish:</b>	
15.6-in, WVA, AntiGlare LED display assembly	591172-001
15.6-in, WVA, BrightView LED display assembly	576803-001
15.6-in, SVA, BrightView LED display assembly	576802-001
<b>With black finish:</b>	
15.6-in, WVA, AntiGlare LED display assembly	591173-001
15.6-in, WVA, BrightView LED display assembly	580127-001
15.6-in, SVA, BrightView LED display assembly	580126-001

Before removing the display assembly, follow these steps:

1. Shut down the computer.
2. Disconnect all external devices connected to the computer.
3. Disconnect the power from the computer by first unplugging the power cord from the AC outlet, and then unplugging the AC adapter from the computer.
4. Remove the battery (see [“Battery” on page 4-7](#)).
5. Remove the memory module compartment cover (see [“Expansion memory module” on page 4-8](#)).
6. Remove the top cover (see [“Top cover” on page 4-10](#)).

Remove the display assembly:

1. Disconnect the following cables:
  - Bluetooth module cable ❶
  - Ambient light sensor module cable ❷
  - Display panel cable ❸
  - Wireless antenna cables ❹

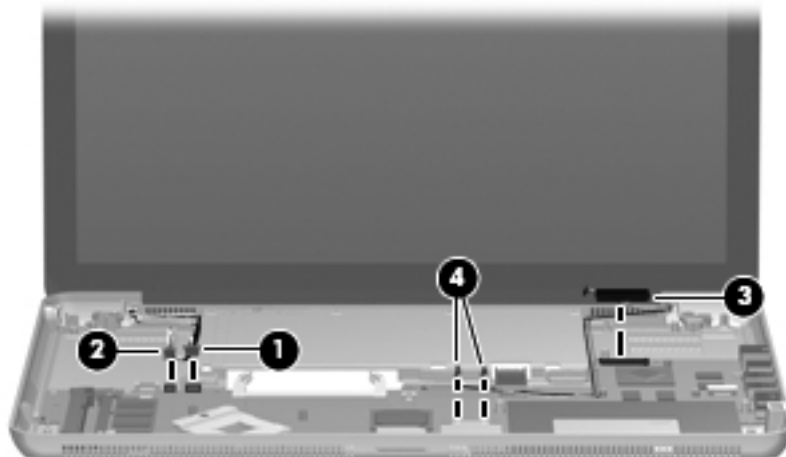

**CAUTION:** Support the display assembly when removing the following screws. Failure to support the display assembly can result in damage to the display assembly and other computer components.

2. Remove the four Phillips PM2.5×6.0 screws ❶ that secure the display assembly to the base enclosure.
3. Lift the display assembly ❷ straight up and remove it.

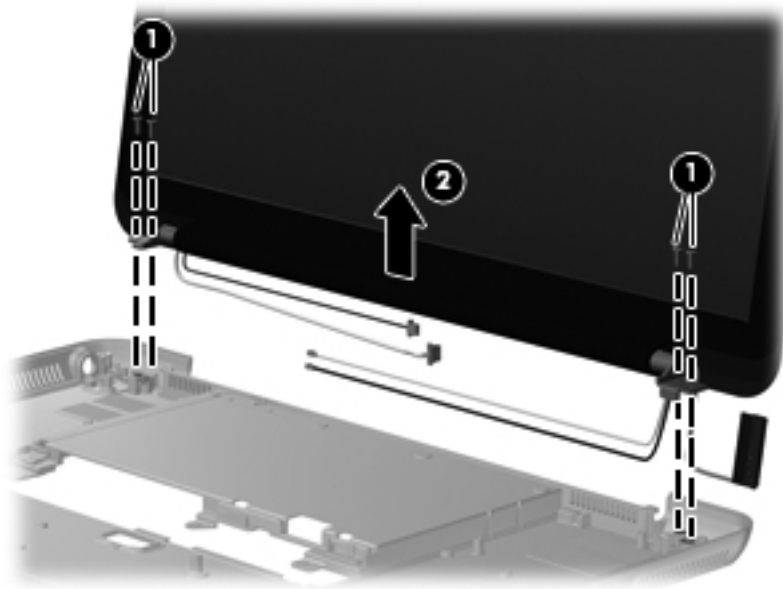

4. If it is necessary to replace the display bezel or any of the display assembly internal components:
  - a. Flex the inside edges of the top edge ❶, the left and right sides ❷, and the bottom edge ❸ of the display bezel until the bezel disengages from the display enclosure.
  - b. Remove the display bezel ❹. The display bezel is available using spare part number 576810-001.

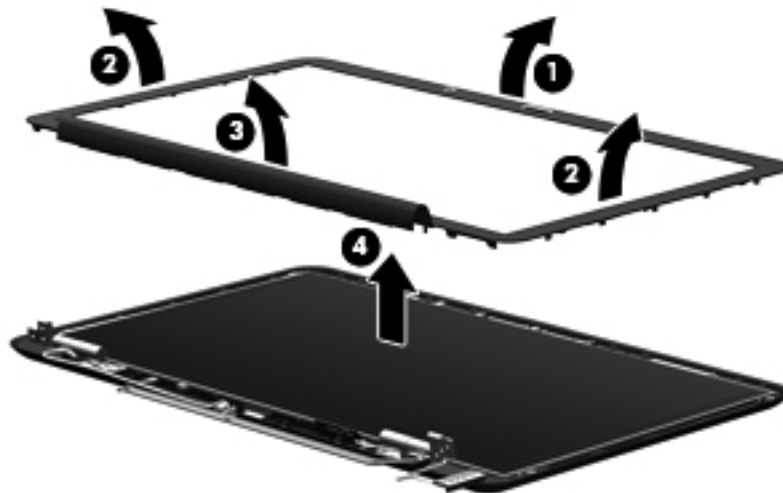



5. If it is necessary to replace the Bluetooth module:
  - a. Release the Bluetooth module ❶ from the rubber clip built into the display enclosure.
  - b. Disconnect the Bluetooth module cable ❷ from the Bluetooth module.

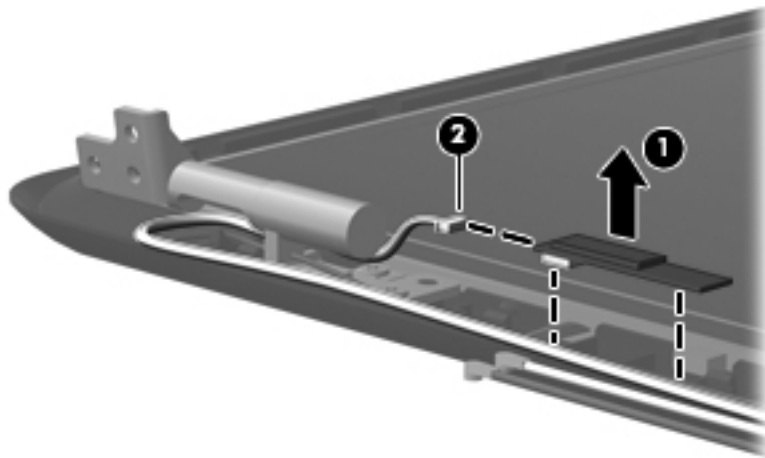

- c. Remove the Bluetooth module. The Bluetooth module is available using spare part number 537921-001.
6. If it is necessary to replace the ambient light sensor module:
  - a. Remove the Phillips PM2.0×3.0 screw ❶ that secures the ambient light sensor module to the display enclosure.
  - b. Release the ambient light sensor module ❷ as far as the ambient light sensor module cable allows.
  - c. Disconnect the ambient light sensor module cable ❸ from the ambient light sensor module.

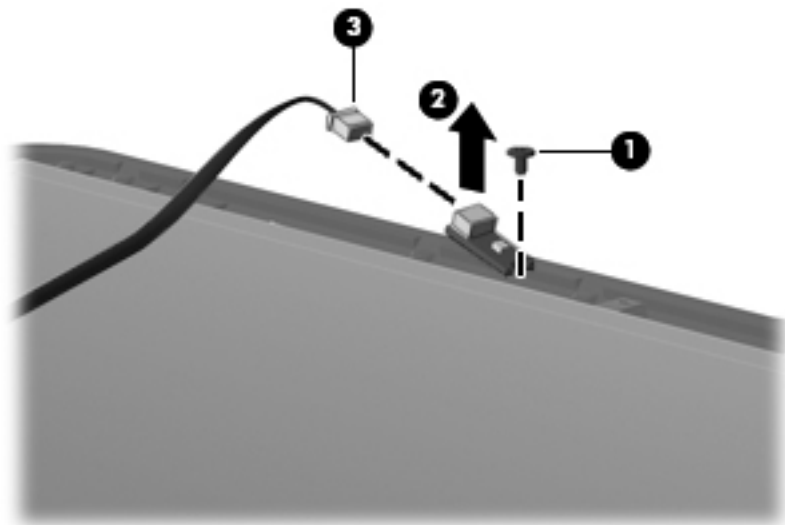

- d. Remove the ambient light sensor module. The ambient light sensor module and cable are available using spare part number 576815-001.

7. If it is necessary to replace the webcam/microphone module:

- a. Release the webcam/microphone module ❶ as far as the webcam/microphone module cable allows.
- b. Disconnect the webcam/microphone module cable ❷ from the webcam/microphone module.

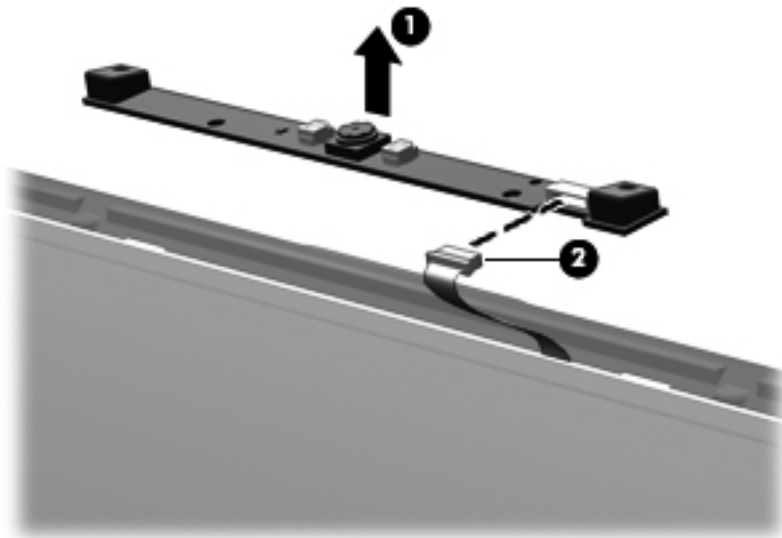

- c. Remove the webcam/microphone module. The webcam/microphone module is available using spare part number 576812-001.

8. If it is necessary to replace the display hinges:

- a. Remove the four Phillips PM2.5×6.0 screws ❶ that secure the display hinges to the display enclosure.
- b. Remove the display hinges ❷. The display hinges are included in the Display Hinge Kit, spare part number 576809-001.

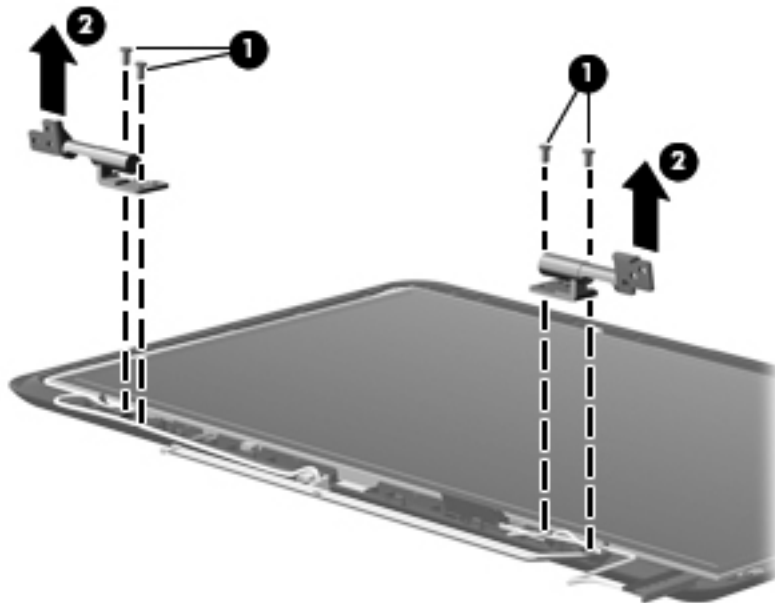

9. If it is necessary to replace the display panel:

- a. Remove the four Phillips PM2.0×4.0 screws ❶ that secure the display panel to the display enclosure.
- b. Release the display panel cable ❷ from the clips and routing channel built into the display enclosure.
- c. Remove the display panel ❸. The display panel is available using the following spare part numbers:
  - ◆ 591327-001—For use only with the 15.6-in, WVA, AntiGlare LED display assembly
  - ◆ 576801-001—For use only with the 15.6-in, WVA, BrightView LED display assembly
  - ◆ 576800-001—For use only with the 15.6-in, SVA, BrightView LED display assembly

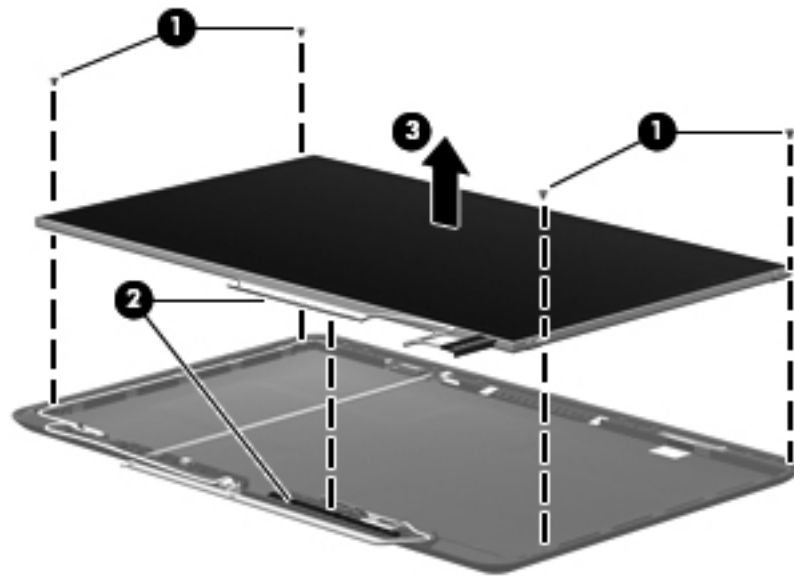

10. If it is necessary to replace the display panel cable:
  - a. Turn the display panel upside down, with the bottom edge toward you.
  - b. Release the support strip ❶ that secures the display panel cable to the display panel.
  - c. Disconnect the display panel cable ❷ from the display panel.
  - d. Remove the display panel cable ❸. (The display panel cable is attached to the display panel with double-sided tape.) The display panel cable is available using spare part number 576813-001.

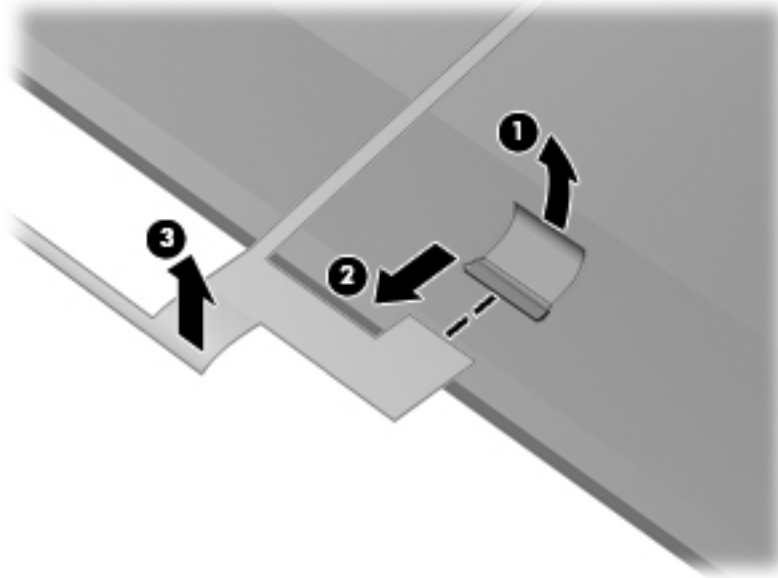

11. If it is necessary to replace the Bluetooth module cable:

- a. Release the Bluetooth module cable from the clips **1** and routing channel built into the bottom edge of the display enclosure.
- b. Remove the Bluetooth module cable **2**. The Bluetooth module cable is available using spare part number 576845-001.

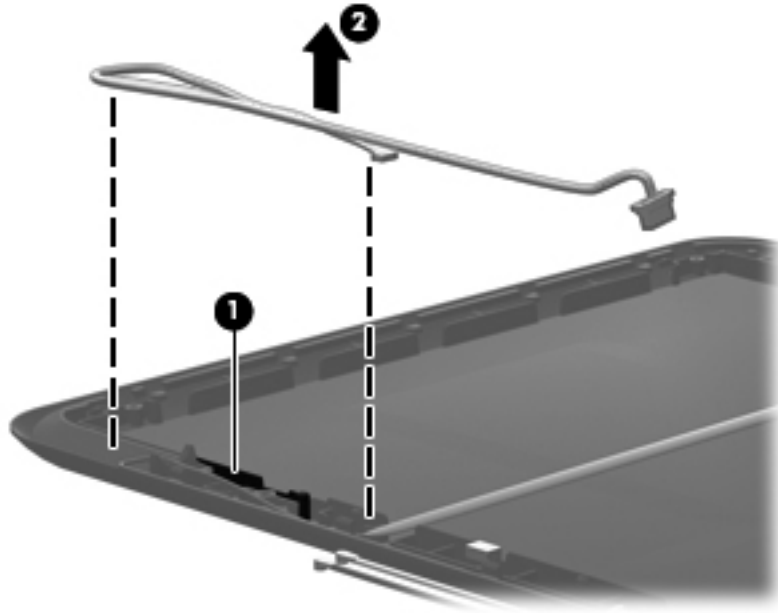

12. If it is necessary to replace the ambient light sensor module cable:

- a. Release the ambient light sensor module cable from the clips **1** and routing channel built into the bottom edge of the display enclosure.
- b. Remove the ambient light sensor module cable **2**. (The ambient light sensor module cable is attached to the display enclosure with double-sided tape.) The ambient light sensor module cable is available using spare part number 576815-001.

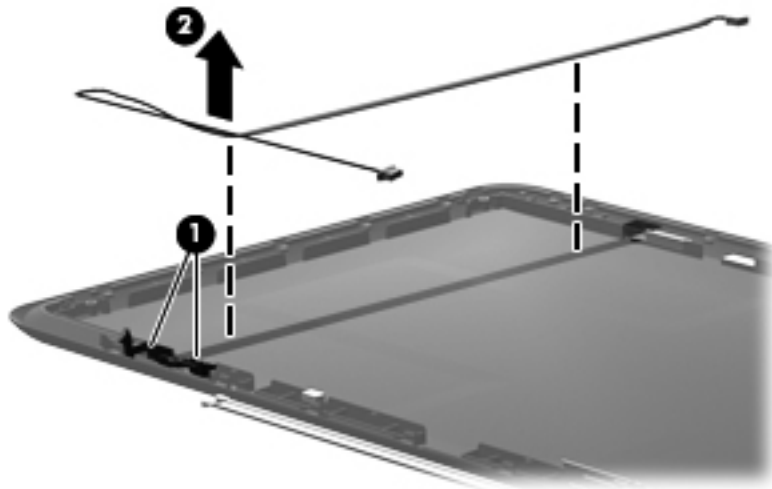

13. If it is necessary to replace the wireless antenna transceivers and cables:

- a. Remove the two Phillips PM2.0×3.0 screws ❶ that secure the wireless antenna transceivers to the display enclosure.
- b. Release the wireless antenna cables from the routing channel ❷ built into the right side of the display enclosure.
- c. Remove the wireless antenna transceivers and cables ❸. The wireless antenna transceivers and cables are available using spare part number 576814-001.

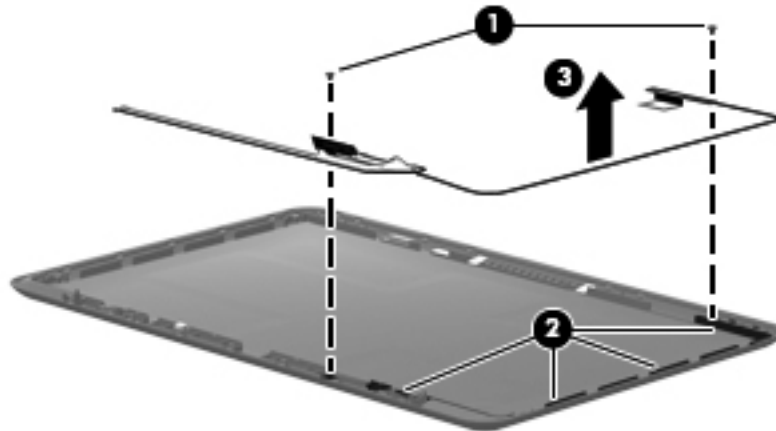

Reverse this procedure to reassemble and install the display assembly.

---

## Setup Utility (BIOS)

### Starting Setup Utility

Setup Utility is a ROM-based information and customization utility that can be used even when your Windows operating system is not working.

The utility reports information about the computer and provides settings for startup, security, and other preferences.

To start Setup Utility:

- » Open Setup Utility by turning on or restarting the computer. While the “Press the ESC key for Startup Menu” message is displayed in the lower-left corner of the screen, press **f10**.
- or –
- 1. Open Setup Utility by turning on or restarting the computer. While the “Press the ESC key for Startup Menu” message is displayed in the lower-left corner of the screen, press **esc**.
- 2. When the Startup Menu is displayed, press **f10**.

### Using Setup Utility

#### Changing the language of Setup Utility

The following procedure explains how to change the language of Setup Utility. If Setup Utility is not already running, begin at step 1. If Setup Utility is already running, begin at step 2.

1. Open Setup Utility by turning on or restarting the computer. While the “Press the ESC key for Startup Menu” message is displayed in the lower-left corner of the screen, press **f10**.
  - or –
  - Open Setup Utility by turning on or restarting the computer. While the “Press the ESC key for Startup Menu” message is displayed in the lower-left corner of the screen, press **esc**. When the Startup Menu is displayed, press **f10**.
2. Use the arrow keys to select **System Configuration > Language**, and then press **enter**.
3. Use the arrow keys to select a language, and then press **enter**.
4. When a confirmation prompt with your language selected is displayed, press **enter**.
5. To save your change and exit Setup Utility, use the arrow keys to select **Exit > Exit Saving Changes**, and then press **enter**.

Your change goes into effect immediately.

## Navigating and selecting in Setup Utility

Because Setup Utility is not Windows based, it does not support the TouchPad. Navigation and selection are by keystroke.

- To choose a menu or a menu item, use the arrow keys.
- To choose an item in a list or to toggle a field, for example an Enable/Disable field, use either the arrow keys or **f5** or **f6**.
- To select an item, press **enter**.
- To close a text box or return to the menu display, press **esc**.
- To display additional navigation and selection information while Setup Utility is open, press **f1**.

## Displaying system information

The following procedure explains how to display system information in Setup Utility. If Setup Utility is not open, begin at step 1. If Setup Utility is open, begin at step 2.

1. Open Setup Utility by turning on or restarting the computer. While the “Press the ESC key for Startup Menu” message is displayed in the lower-left corner of the screen, press **f10**.  
– or –  
Open Setup Utility by turning on or restarting the computer. While the “Press the ESC key for Startup Menu” message is displayed in the lower-left corner of the screen, press **esc**. When the Startup Menu is displayed, press **f10**.
2. Select the **Main** menu. System information such as the system time and date, and identification information about the computer is displayed.
3. To exit Setup Utility without changing any settings, use the arrow keys to select **Exit > Exit Discarding Changes**, and then press **enter**.

## Restoring default settings in Setup Utility

The following procedure explains how to restore the Setup Utility default settings. If Setup Utility is not already running, begin at step 1. If Setup Utility is already running, begin at step 2.

1. Open Setup Utility by turning on or restarting the computer. While the “Press the ESC key for Startup Menu” message is displayed in the lower-left corner of the screen, press **f10**.  
– or –  
Open Setup Utility by turning on or restarting the computer. While the “Press the ESC key for Startup Menu” message is displayed in the lower-left corner of the screen, press **esc**. When the Startup Menu is displayed, press **f10**.
2. Use the arrow keys to select **Exit > Load Setup Defaults**, and then press **enter**.
3. When the Setup Confirmation is displayed, press **enter**.
4. To save your change and exit Setup Utility, use the arrow keys to select **Exit > Exit Saving Changes**, and then press **enter**.

The Setup Utility default settings go into effect when the computer restarts.



Your password, security, and language settings are not changed when you restore the factory default settings.



## Exiting Setup Utility

You can exit Setup Utility with or without saving changes.

- To exit Setup Utility and save your changes from the current session:

If the Setup Utility menus are not visible, press **esc** to return to the menu display. Then use the arrow keys to select **Exit > Exit Saving Changes**, and then press **enter**.

- To exit Setup Utility without saving your changes from the current session:

If the Setup Utility menus are not visible, press **esc** to return to the menu display. Then use the arrow keys to select **Exit > Exit Discarding Changes**, and then press **enter**.

After either choice, the computer restarts in Windows.

## Setup Utility menus

The menu tables in this section provide an overview of Setup Utility options.



Some of the Setup Utility menu items listed in this chapter may not be supported by your computer.

### Main menu

Select	To do this
System Information	<ul style="list-style-type: none"> <li>■ View and change the system time and date.</li> <li>■ View identification information about the computer.</li> <li>■ View specification information, such as processor information, memory size, and system BIOS.</li> </ul>

### Security menu

Select	To do this
Administrator password	Enter, change, or delete an administrator password.
Power-On Password	Enter, change, or delete a power-on password.

## System Configuration menu

Select	To do this
Language Support	Change the Setup Utility language.
Virtualization Technology (select models only)	Enable/disable the processor Virtualization Technology.
Fan Always On	Enable/disable Fan Always On. When enabled, the computer fan will always be on.
Fast Charge Mode	Enable/disable the Fast Charge Mode for the primary and accessory batteries.
Action Key Mode	Enable/disable the Action Key Mode.
Boot Options	<p>Set the following boot options:</p> <ul style="list-style-type: none"> <li>■ POST Hot Key Delay (sec.)—Set the delay for the user to press hotkeys in intervals of 5 seconds each (0, 5, 10, 15, 20).</li> <li>■ IOS: <ul style="list-style-type: none"> <li><input type="checkbox"/> Enable/disable IOS.</li> <li><input type="checkbox"/> Set the delay for the user to start Windows in intervals of 5 seconds each (0, 5, 10, 15, 20).</li> </ul> </li> <li>■ Floppy Boot—Enable/disable boot from diskette.</li> <li>■ Network Adapter Boot—Enable/disable boot from external Network Adapter.</li> <li>■ Boot Order—Set the boot order for: <ul style="list-style-type: none"> <li><input type="checkbox"/> Notebook Hard Drive</li> <li><input type="checkbox"/> USB Diskette on Key/USB Hard Drive</li> <li><input type="checkbox"/> USB CD/DVD ROM Drive</li> <li><input type="checkbox"/> USB Floppy</li> <li><input type="checkbox"/> Network adapter</li> </ul> </li> </ul>

## Diagnostics menu

Select	To do this
Primary Hard Disk Self Test	Run a comprehensive self-test on the primary hard drive.
Secondary Hard Disk Self Test (select models only)	Run a comprehensive self-test on the secondary hard drive.
Memory Test	Run a diagnostic test on the system memory.

## Updating the BIOS

Updated versions of the BIOS may be available on the HP Web site.

Most BIOS updates on the HP Web site are packaged in compressed files called *SoftPaqs*.

Some download packages contain a file named *Readme.txt*, which contains information regarding installing and troubleshooting the file.

## Updating the BIOS

### Determining the BIOS version

To determine whether available BIOS updates contain later BIOS versions than those currently installed on the computer, you need to know the version of the system BIOS currently installed.

BIOS version information (also known as *ROM date* and *System BIOS*) can be displayed by pressing **fn+esc** (if you are already in Windows) or by opening Setup Utility.

To use Setup Utility for displaying BIOS information:

1. Open Setup Utility by turning on or restarting the computer. While the “Press the ESC key for Startup Menu” message is displayed in the lower-left corner of the screen, press **f10**.
2. If Setup Utility does not open with the system information displayed, use the arrow keys to select the **Main** menu.

When the Main menu is selected, BIOS and other system information is displayed.

3. To exit Setup Utility, use the arrow keys to select **Exit > Exit Discarding Changes**, and then press **enter**.

## Downloading a BIOS update



**CAUTION:** To prevent damage to the computer or an unsuccessful installation, download and install a BIOS update only when the computer is connected to reliable external power using the AC adapter. Do not download or install a BIOS update while the computer is running on battery power, docked in an optional docking device, or connected to an optional power source. During the download and installation, follow these instructions:

Do not disconnect power from the computer by unplugging the power cord from the AC outlet.

Do not shut down the computer or initiate Sleep or Hibernation.

Do not insert, remove, connect, or disconnect any device, cable, or cord.

---

To download a BIOS update:

1. Access the page on the HP Web site that provides software for your computer:  
Select **Start > Help and Support > Maintain**.
2. Follow the instructions on the screen to identify your computer and access the BIOS update you want to download.
3. At the download area, follow these steps:
  - a. Identify the BIOS update that is later than the BIOS version currently installed on your computer. Make a note of the date, name, or other identifier. You may need this information to locate the update later, after it has been downloaded to your hard drive.
  - b. Follow the instructions on the screen to download your selection to the hard drive.  
Make a note of the path to the location on your hard drive where the BIOS update will be downloaded. You will need to access this path when you are ready to install the update.



If you connect your computer to a network, consult the network administrator before installing any software updates, especially system BIOS updates.

BIOS installation procedures vary. Follow any instructions that are displayed on the screen after the download is complete. If no instructions are displayed, follow these steps:

1. Open Windows Explorer by selecting **Start > Computer**.
  2. Double-click your hard drive designation. The hard drive designation is typically Local Disk (C:).
  3. Using the hard drive path you recorded earlier, open the folder on your hard drive that contains the update.
  4. Double-click the file that has an .exe extension (for example, *filename.exe*).  
The BIOS installation begins.
  5. Complete the installation by following the instructions on the screen.
- 



After a message on the screen reports a successful installation, you can delete the downloaded file from your hard drive.

---

# Specifications

## Computer specifications

	Metric	U.S.
<b>Computer dimensions</b>		
Width	38.0 cm	14.96 in
Depth	24.4 cm	9.60 in
Height	2.65 cm	1.04 in
<b>Computer weight</b>		
	2.35 kg	5.18 lbs
<b>Optional accessory battery dimensions</b>		
Width	36.37 cm	13.13 in
Depth	22.77 cm	8.96 in
Height	0.94 cm	0.37 in
<b>Optional accessory battery weight</b>		
	1.25 kg	2.76 lbs
<b>Input power</b>		
Operating voltage	19.0 V dc @ 3.42 A - 90 W	
Operating current	3.42 A	
<b>Temperature</b>		
Operating (writing to optical disc)	5°C to 35°C	41°F to 95°F
Nonoperating	-20°C to 60°C	-4°F to 140°F
<b>Relative humidity (noncondensing)</b>		
Operating	10% to 90%	
Nonoperating	5% to 95%	
<b>Maximum altitude (unpressurized)</b>		
Operating	-15 m to 3,048 m	-50 ft to 10,000 ft
Nonoperating	-15 m to 12,192 m	-50 ft to 40,000 ft
 Applicable product safety standards specify thermal limits for plastic surfaces. The computer operates well within this range of temperatures.		

## 15.6-in display specifications

	Metric	U.S.
<b>Dimensions</b>		
Height	19.5 cm	7.67 in
Width	34.5 cm	13.58 in
Diagonal	39.4 cm	15.51 in
<b>Number of colors</b>	Up to 16.8 million	
<b>Contrast ratio</b>	250:1 (typical)	
<b>Brightness</b>	370 nits (typical)	
<b>Pixel resolution</b>		
Pitch	0.279 × 0.279 mm	
Format	1920 × 1080 (FHD) or 1368 × 768 (HD)	
Configuration	RGB vertical stripe	
<b>Backlight</b>	LED	
<b>Character display</b>	80 × 25	
<b>Total power consumption</b>	4.0 W	
<b>Viewing angle</b>	±40° horizontal, +120°/-40° vertical (typical)	

## Hard drive specifications

### 9.5-mm, 2.5-in hard drive

	640-GB*	500-GB*	320-GB*	250-GB*
<b>Dimensions</b>				
Height	9.5 mm	9.5 mm	9.5 mm	9.5 mm
Width	70 mm	70 mm	70 mm	70 mm
Weight	101 g	101 g	101 g	101 g
<b>Interface type</b>	SATA	SATA	SATA	SATA
<b>Transfer rate</b>	100 MB/sec	100 MB/sec	100 MB/sec	100 MB/sec
<b>Security</b>	ATA security	ATA security	ATA security	ATA security
<b>Seek times</b> (typical read, including setting)				
Single track	1.5 ms	1.5 ms	2.0 ms	2.0 ms
Average	12.0 ms	12.0 ms	12.0 ms	12.0 ms
Maximum	22.0 ms	22.0 ms	22.0 ms	22.0 ms
<b>Logical blocks</b>	1,250,327,040	976,818,008	625,163,520	488,409,016
<b>Disc rotational speed</b>	7200 rpm	7200 rpm	7200 rpm	7200 rpm
<b>Operating temperature</b>	5°C to 55°C (41°F to 131°F)			

\*1 GB = 1 billion bytes when referring to hard drive storage capacity. Actual accessible capacity is less. Actual drive specifications may differ slightly.



Certain restrictions and exclusions apply. Contact technical support for details.

## 8.0-mm, 1.8-in hard drive

	320-GB*	250-GB*	160-GB*
<b>Dimensions</b>			
Height	8.0 mm	8.0 mm	8.0 mm
Width	70 mm	70 mm	70 mm
Weight	101 g	101 g	101 g
<b>Interface type</b>	SATA	SATA	SATA
<b>Transfer rate</b>	100 MB/sec	100 MB/sec	100 MB/sec
<b>Security</b>	ATA security	ATA security	ATA security
<b>Seek times</b> (typical read, including setting)			
Single track	1.5 ms	2.0 ms	2.0 ms
Average	12.0 ms	12.0 ms	12.0 ms
Maximum	22.0 ms	22.0 ms	22.0 ms
<b>Logical blocks</b>	625,163,520	488,409,016	312,581,760
<b>Disc rotational speed</b>	5400 rpm	5400 rpm	5400 rpm
<b>Operating temperature</b>	5°C to 55°C (41°F to 131°F)		
*1 GB = 1 billion bytes when referring to hard drive storage capacity. Actual accessible capacity is less. Actual drive specifications may differ slightly.			
 Certain restrictions and exclusions apply. Contact technical support for details.			



## Blu-ray ROM DVD±R/RW SuperMulti Double-Layer Drive specifications

<b>Applicable disc</b>	<b>Read:</b>	<b>Write:</b>
	BD-ROM, BD-ROM-DL, BD-R, BD-R-DL, BD-RE, BD-RE-DL, DVD-ROM, DVD+R, DVD+R-DL, DVD+RW, DVD-R, DVD-R-DL, DVD-RW, DVD-RAM (Ver.2), CD-DA, CD-ROM (mode 1 and mode 2), CD-ROM XA (mode 2, form 1 and form 2), Photo CD (single and multiple sessions), CD Extra, CD-R, CD-RW, and CD-TEXT	DVD-RAM (Ver.2), DVD+R, DVD-R, CD-R, and CD-ROM
<b>Access time</b>	<b>BD</b>	<b>DVD</b>
Random	< 230 ms	< 180 ms
<b>Cache buffer</b>	4.5 MB	
<b>Data transfer rate</b>		
2X BD-RAM	9 MB/sec	
8X DVD	2,400 KB/sec	
16X CD-R	2,400 KB/sec	
16X CD-RW	2,400 KB/sec	

## DVD±RW and CD-RW SuperMulti Double-Layer Combo Drive specifications

<b>Applicable disc</b>	<b>Read:</b>	<b>Write:</b>
	CD-DA, CD+(E)G, CD-MIDI, CD-TEXT, CDROM, CD-ROM XA, MIXED MODE CD, CD-I, CD-I Bridge (Photo-CD, Video CD), Multisession CD (Photo-CD, CD-EXTRA, Portfolio, CD-R, CD-RW), CD-R, CD-RW, DVD-ROM (DVD-5, DVD-9, DVD-10, DVD-18), DVD-R, DVD-RW, DVD+R, DVD+RW, DVD-RAM	CD-R and CD-RW DVD+R, DVD+RW, DVD-R, DVD-RW, DVD-RAM
<b>Access time</b>	<b>CD</b>	<b>DVD</b>
Random	< 175 ms	< 230 ms
<b>Cache buffer</b>	2.5 MB	
<b>Data transfer rate</b>		
24X CD-ROM	3,600 KB/sec	
8X DVD	10,800 KB/sec	
24X CD-R	3,600 KB/sec	
16X CD-RW	2,400 KB/sec	
8x DVD+R	10,800 KB/sec	
4X DVD+RW	5,400 KB/sec	
8X DVD-R	10,800 KB/sec	
4X DVD-RW	5,400 KB/sec	
2.4X DVD+R(9)	2,700 KB/sec	
5X DVD-RAM	6,750 KB/sec	
<b>Transfer mode</b>	Multiword DMA mode	

## System DMA specifications

Hardware	DMA system function
DMA0	Not applicable
DMA1*	Not applicable
DMA2*	Not applicable
DMA3	Not applicable
DMA4	Direct memory access controller
DMA5*	Not applicable
DMA6	Not assigned
DMA7	Not assigned

\*ExpressCard controller can use DMA 1, 2, or 5.

## System memory map specifications

Size	Memory address	System function
640 KB	00000000–0009FFFF	Base memory
128 KB	000A0000–000BFFFF	Video memory
64 KB	000C0000–000CFFFF	Video BIOS
64 KB	000E8000–000FFFFF	System BIOS
	00100000–XFFFFFFFF	Extended memory (based on memory installed)
	(X+1)0000000–FEDFFFFFF	PCI bus
	FED00000–FED003FF	High-precision event timer
	FEE01000–FFFFFFFF	PCI bus

## System interrupt specifications

Hardware IRQ	System function
IRQ0	System timer
IRQ1	Standard 101-/102-key or Microsoft natural keyboard
IRQ8	System CMOS/real-time clock
IRQ12	Synaptics PS/2 TouchPad
IRQ13	Numeric data processor
IRQ16	Intel ICH9 family USB universal host controller 2937 Mobile Intel 5 Series express chipset family
IRQ17*	High-definition audio controller Intel ICH9 family USB universal host controller 2938 Marvell Yukon 88E8072 PCIE-gigabit Ethernet controller
IRQ18	Intel ICH9 family USB universal host controller 2939 Intel ICH9 family USB universal host controller 2936
IRQ19	Intel ICH9 family USB2 enhanced controller 293C
IRQ20	Intel ICH9 family USB2 enhanced controller 293A Intel ICH9 family USB universal host controller 2934
IRQ21	Intel ICH9M-E/M SATA AHCI controller
IRQ22	Intel ICH9 family USB universal host controller 2935

\*Default configuration; other possible audio configurations are IRQ5, IRQ7, IRQ9, IRQ10, or none.

 ExpressCards may assert IRQ3, IRQ4, IRQ5, IRQ7, IRQ9, IRQ10, IRQ11, or IRQ15. Either the infrared or the serial port may assert IRQ3 or IRQ4.

 For operating systems after Windows 2000, APIC (advanced programming interrupt controller) is used.

## System I/O address specifications

I/O address (hex)	System function (shipping configuration)
000–01F	DMA controller
020–021	Program interrupt controller
024–025	Program interrupt controller
028–029	Program interrupt controller
02C–03D	Program interrupt controller
02E–02F	Motherboard resources
030–031	Program interrupt controller
034–035	Program interrupt controller
038–039	Program interrupt controller
03C–03D	Program interrupt controller
040–043	System timer
04E–04F	Motherboard resources
050–053	System timer
060	Standard 101-/102-key or Microsoft natural keyboard
061	Motherboard resources
062	Microsoft ACPI-compliant embedded controller
063	Motherboard resources
064	Standard 101-/102-key or Microsoft natural keyboard
065	Motherboard resources
066	Microsoft ACPI-compliant embedded controller
067	Motherboard resources
070	Motherboard resources
071–077	System CMOS/real-time clock
080	Motherboard resources
081–091	Direct memory access controller
092	Motherboard resources
093–09F	Direct memory access controller
0A0–0A1	Program interrupt controller
0A4–0A5	Program interrupt controller
0A8–0A9	Program interrupt controller
0AC–0AD	Program interrupt controller
0B0–0B1	Program interrupt controller
0B2–0B3	Motherboard resources
0B4–0B5	Program interrupt controller
0B8–0B9	Program interrupt controller
0BC–0BD	Program interrupt controller

(Continued)

<b>I/O address (hex)</b>	<b>System function (shipping configuration)</b>
0C0–0DF	Direct memory access controller
0F0–0F0	Numeric data processor
0200–027F	Motherboard resources
3B0–3BB	Mobile Intel 5 Series express chipset family
3C0–3DF	Mobile Intel 5 Series express chipset family
400–47F	Motherboard resources
4D0–4D1	Programmable interrupt controller
500–57F	Motherboard resources
1000–1003	Motherboard resources
1010–101F	Motherboard resources
2000–20FF	Marvell Yukon 88E8072 PCIe-gigabit Ethernet controller
2000–2FFF	ICH9 family PCI express root port6-294A
3000–4FFF	ICH9 family PCI express root port5-2948
5000–6FFF	ICH9 family PCI express root port3-2944
7000–701F	ICH9M-E/M SATA AHCI controller
7020–703F	ICH9 family USB universal host controller 2936
7040–705F	ICH9 family USB universal host controller 2935
7060–707F	ICH9 family USB universal host controller 2934
7080–709F	ICH9 family USB universal host controller 2939
70A0–70BF	ICH9 family USB universal host controller 2938
70C0–70DF	ICH9 family USB universal host controller 2937
70E0–70E7	ICH9M-E/M SATA AHCI controller
70E8–70EF	ICH9M-E/M SATA AHCI Controller
70F0–70F7	Mobile Intel 5 Series express chipset family
70F8–70FB	ICH9M-E/M SATA AHCI controller
70FC–70FF	ICH9M-E/M SATA AHCI controller
EF80–EF9F	Motherboard resources
FE00–FE0F	Motherboard resources
FE80–EF8F	Motherboard resources
FFFF	Motherboard resources

## Screw listing

This chapter provides specification and reference information for the screws used in the computer. The screws listed in this chapter are available in the Screw Kit, spare part number 576844-001.

### Phillips PM2.0×4.0 screw

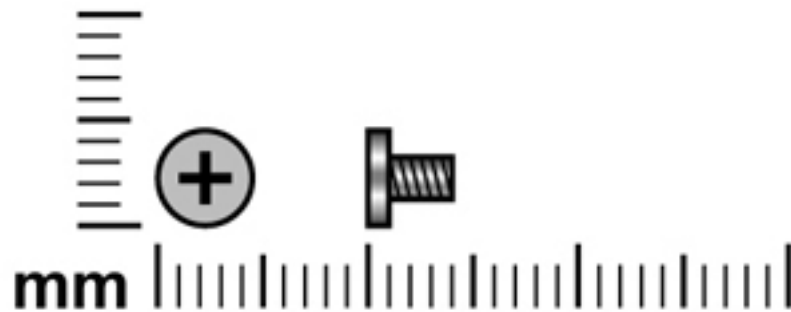

Color	Quantity	Length	Thread	Head diameter
Silver	14	4.0 mm	2.0 mm	4.5 mm

**Where used:** 3 screws that secure the memory module compartment cover to the computer

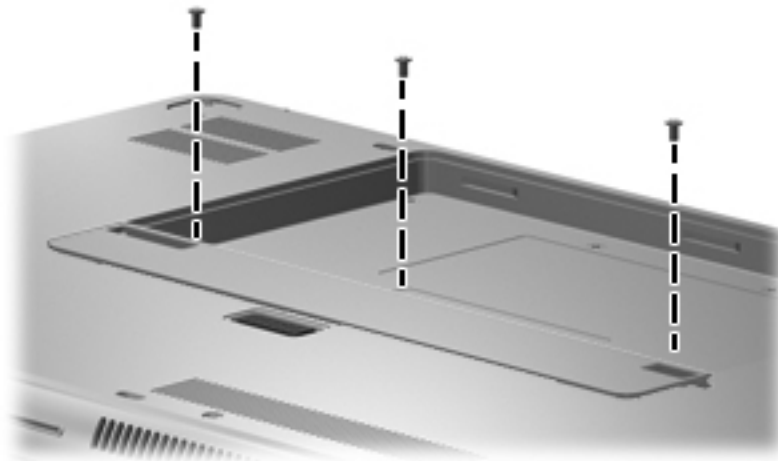

**Where used:**

- ❶ Two screws that secure the speaker assembly to the base enclosure
- ❷ One screw that secures the WLAN module to the system board

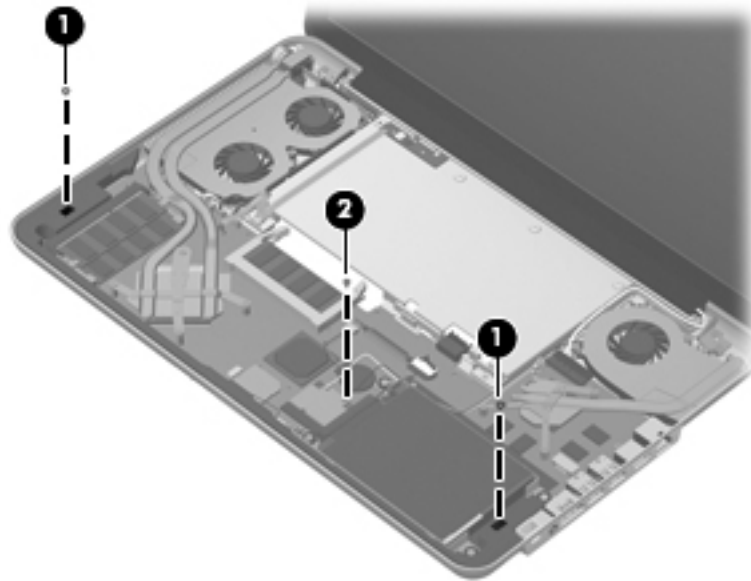

**Where used:** 4 screws that secure the system board to the base enclosure

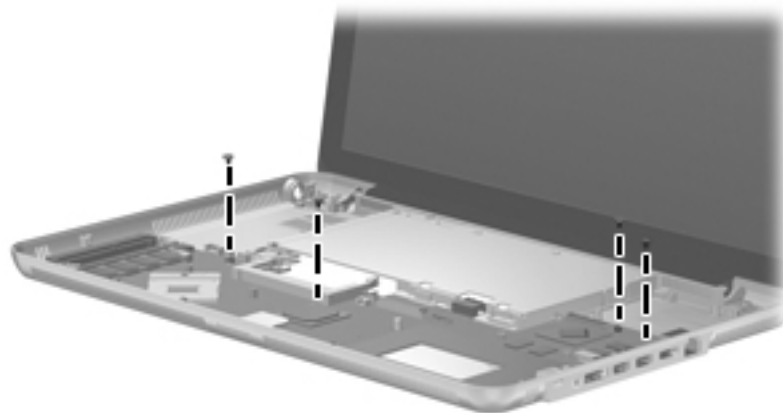

**Where used:** 4 screws that secure the display panel to the display enclosure

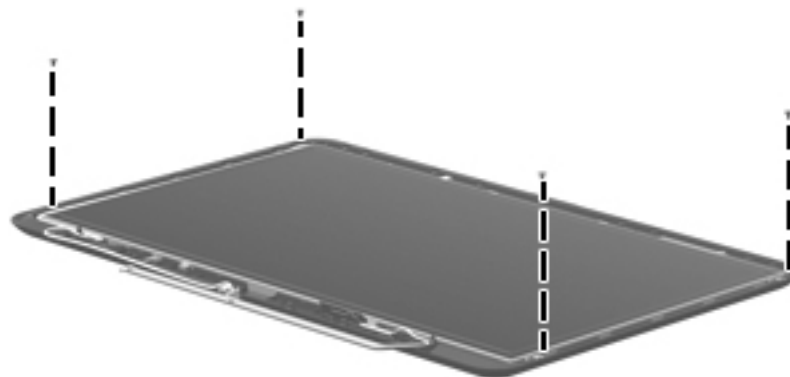



## Phillips PM2.0×12.0 screw

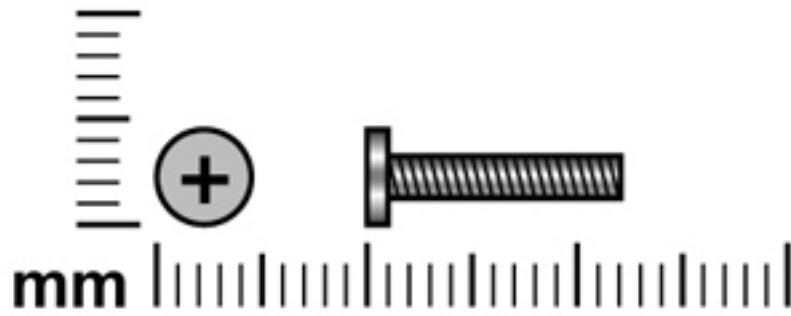

Color	Quantity	Length	Thread	Head diameter
Silver	8	12.0 mm	2.0 mm	5.0 mm

**Where used:** 8 screws that secure the top cover to the base enclosure

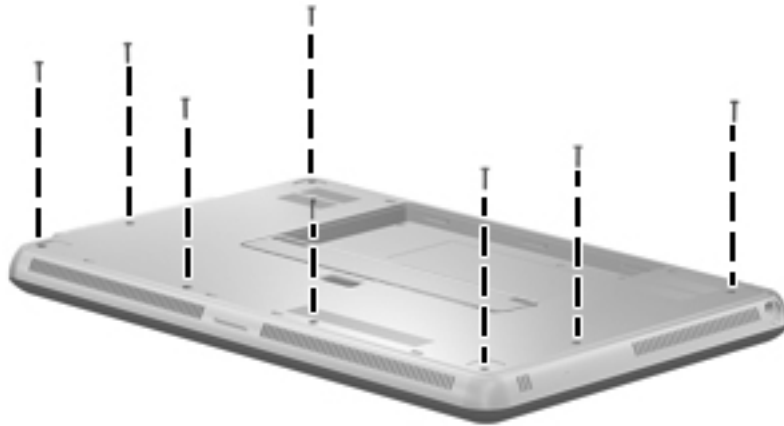

## Phillips PM2.0×5.0 screw

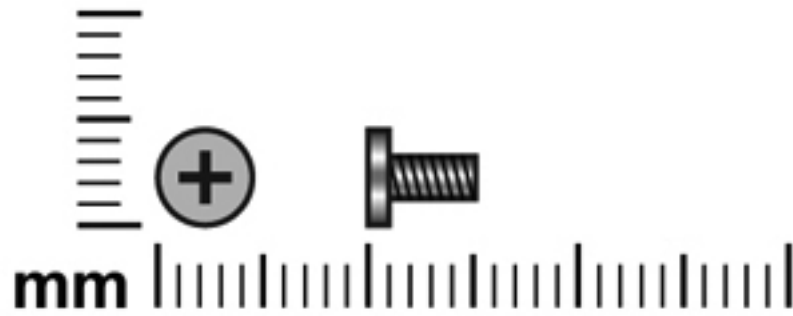

Color	Quantity	Length	Thread	Head diameter
Silver	2	5.0 mm	2.0 mm	5.0 mm

**Where used:** 2 screws that secure the top cover to the base enclosure

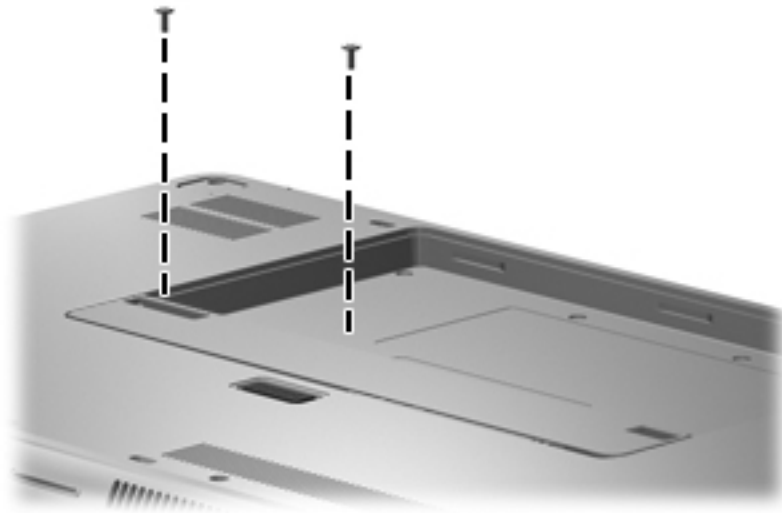

## Phillips PM2.0×2.0 screw

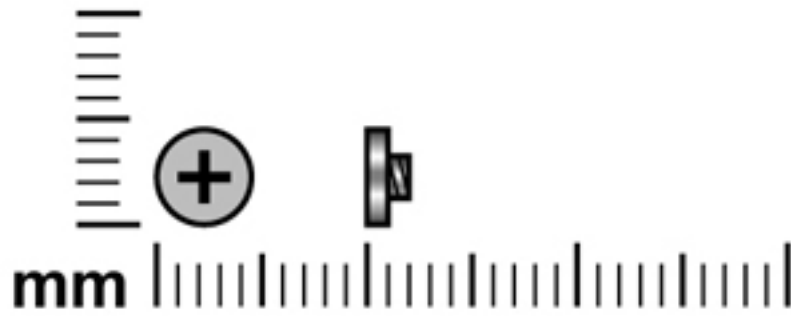

Color	Quantity	Length	Thread	Head diameter
Silver	4	2.0 mm	2.0 mm	4.5 mm

**Where used:** 4 screws that secure the top cover to the base enclosure

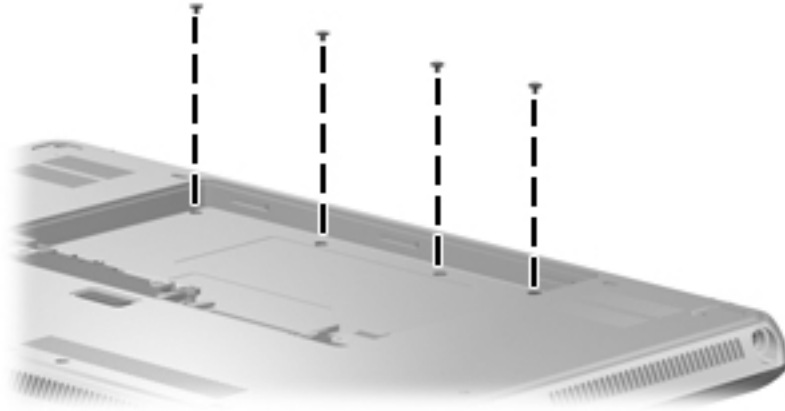

## Phillips PM1.5×1.5 screw



Color	Quantity	Length	Thread	Head diameter
Silver	60	1.5 mm	1.5 mm	3.0 mm

**Where used:** 60 screws that secure the keyboard to the top cover

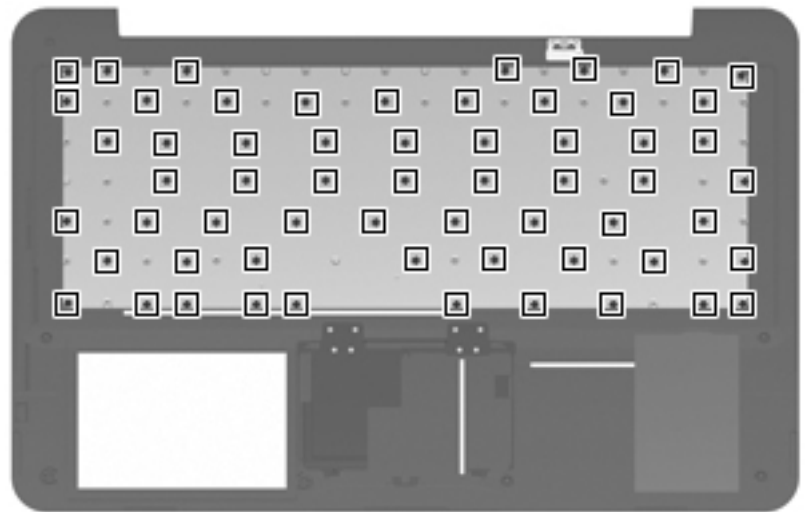

## Phillips PM2.0×4.0 broadhead screw

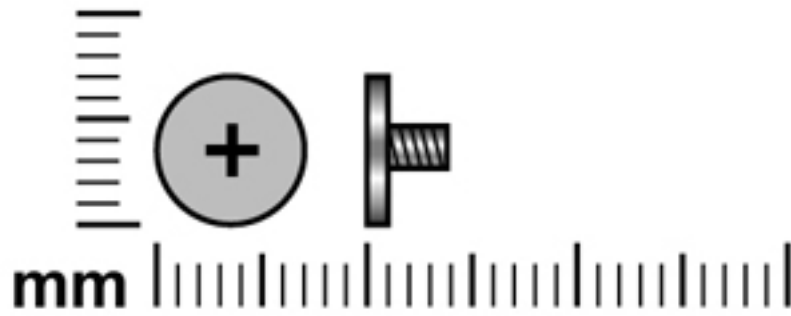

Color	Quantity	Length	Thread	Head diameter
Silver	2	4.0 mm	2.0 mm	6.0 mm

**Where used:** 2 screws that secure the hard drive to the base enclosure

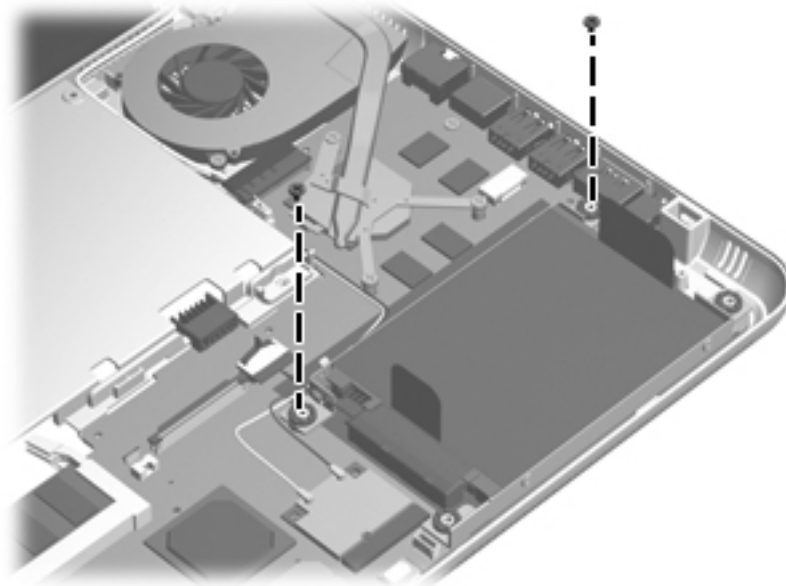

## Phillips PM3.0×4.0 screw

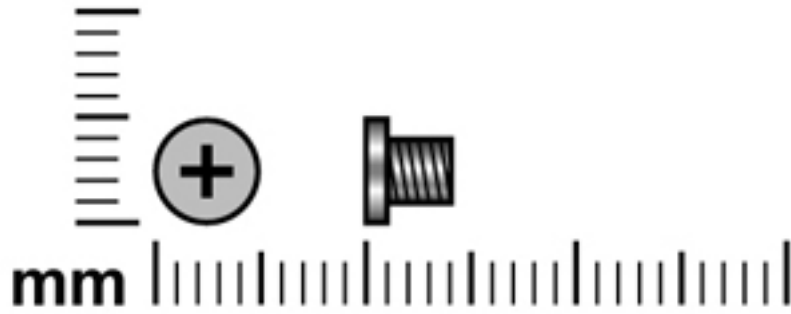

Color	Quantity	Length	Thread	Head diameter
Silver	4	4.0 mm	3.0 mm	5.0 mm

**Where used:** 4 screws that secure the hard drive bracket to the hard drive

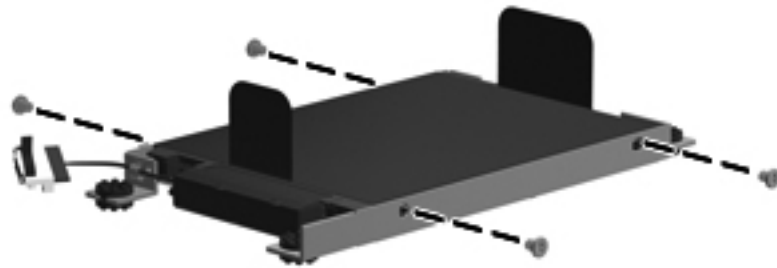

## Phillips PM2.0×6.0 captive screw

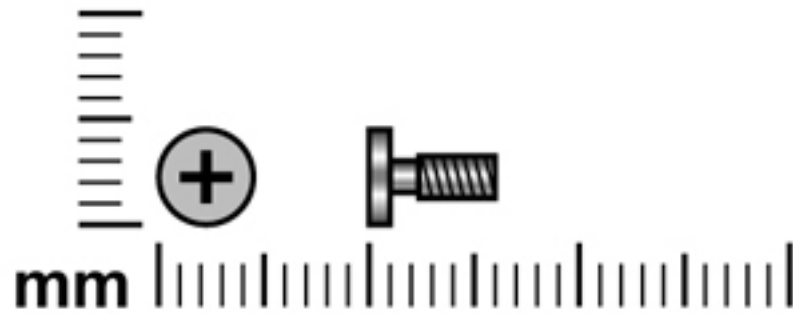

Color	Quantity	Length	Thread	Head diameter
Silver	7	6.0 mm	2.0 mm	5.0 mm

### Where used:

- ❶ Four captive screws that secure the processor fan/heat sink assembly to the system board (screws are secured to the heat sink by O-rings)
- ❷ Three captive screws that secure the video fan/heat sink assembly to the system board (screws are secured to the heat sink by O-rings)

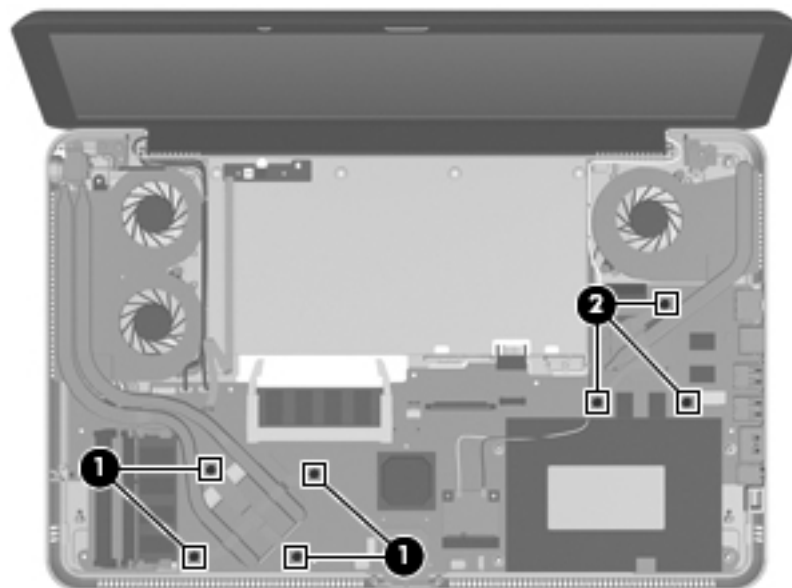

## Phillips PM2.0×3.0 screw

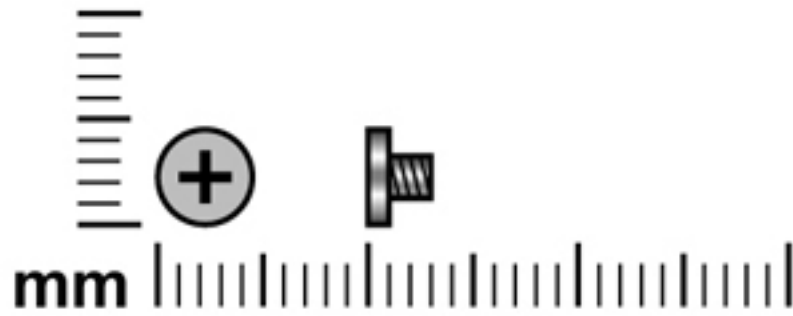

Color	Quantity	Length	Thread	Head diameter
Silver	8	3.0 mm	2.0 mm	4.5 mm

### Where used:

- ❶ One screw that secures the processor fan/heat sink assembly to the system board
- ❷ Two screws that secure the video fan/heat sink assembly to the system board

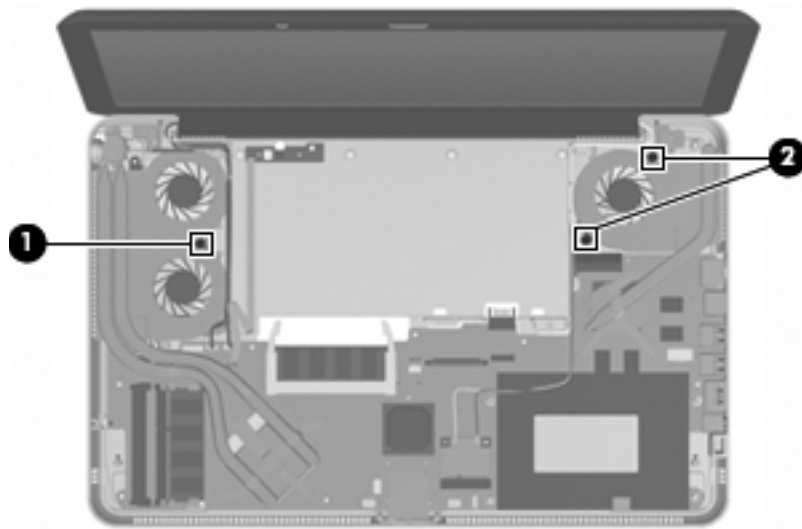



**Where used:** 2 screws that secure the power connector bracket and power connector to the base enclosure

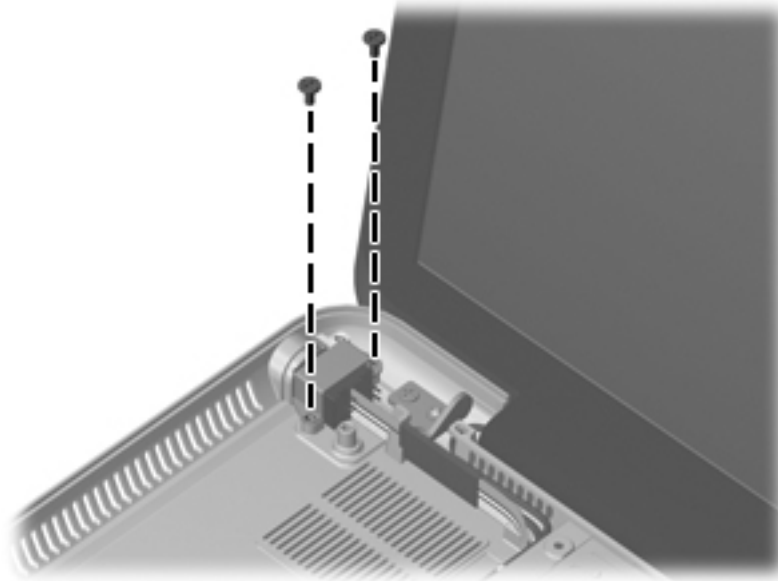

**Where used:** One screw that secures the ambient light sensor module to the display enclosure

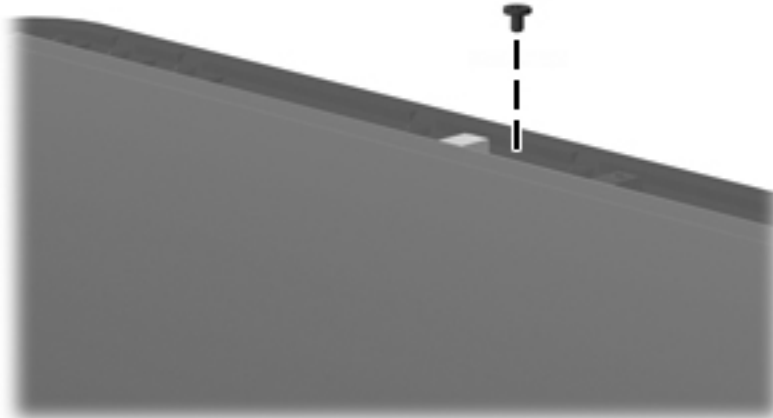

**Where used:** 2 screws that secure the wireless antenna transceivers to the display enclosure

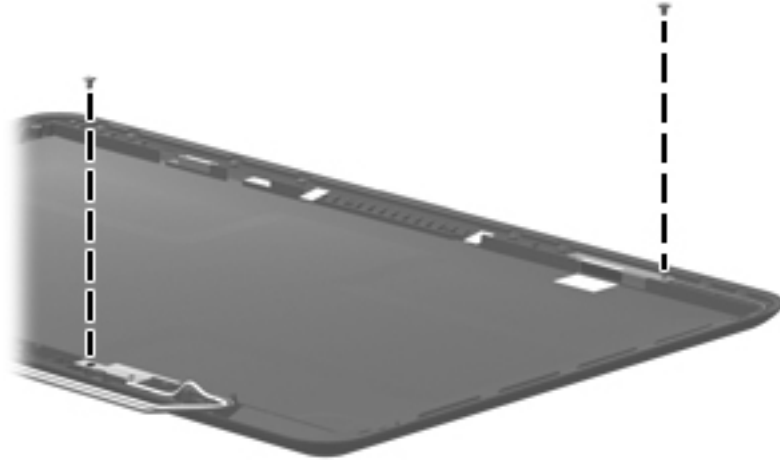

## Phillips PM2.5×6.0 screw

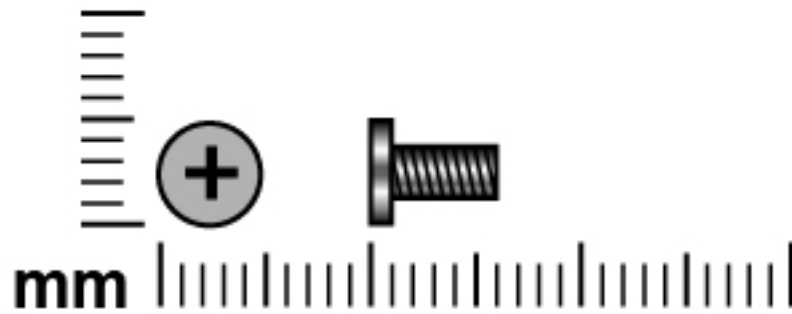

Color	Quantity	Length	Thread	Head diameter
Silver	8	6.0 mm	2.5 mm	5.0 mm

**Where used:** 4 screws that secure the display assembly to the base enclosure

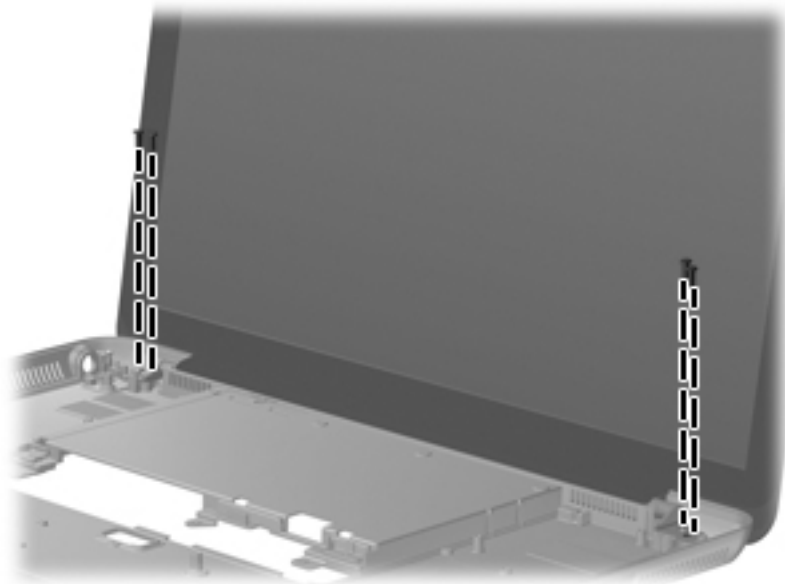

**Where used:** 4 screws that secure the display hinges to the display enclosure

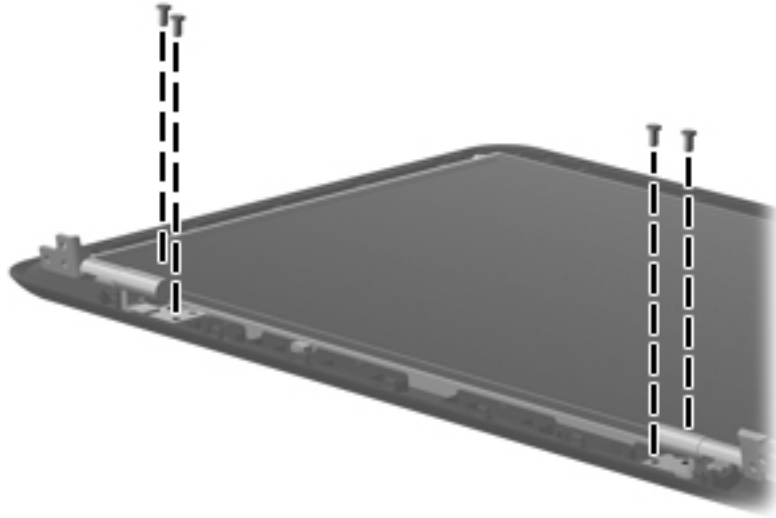

---

## Backup and recovery

Recovery after a system failure is as complete as your most current backup. HP recommends that you create recovery discs immediately after software setup. As you add new software and data files, you should continue to back up your system on a regular basis to maintain a reasonably current backup.

Tools provided by the operating system and HP Recovery Manager software are designed to help you with the following tasks for safeguarding your information and restoring it in case of a system failure:

- Creating a set of recovery discs (Recovery Manager software feature). Recovery discs are used to start up (boot) your computer and restore the operating system and software programs to factory settings in case of system failure or instability.
- Backing up your information regularly to protect your important system files.
- Creating system restore points (operating system feature). System restore points allow you to reverse undesirable changes to your computer by restoring the computer to an earlier state.
- Recovering a program or driver (Recovery Manager software feature). This feature helps you reinstall a program or driver without performing a full system recovery.
- Performing a full system recovery (Recovery Manager software feature). With Recovery Manager, you can recover your full factory image if you experience system failure or instability. Recovery Manager works from a dedicated recovery partition (select models only) on the hard drive or from recovery discs you create.



Computers with a solid-state drive (SSD) may not have a recovery partition. Recovery discs have been included for computers that do not have a partition. Use these discs to recover your operating system and software. To check for the presence of a recovery partition, click **Start**, right-click **Computer**, click **Manage**, and then click **Disk Management**. If the partition is present, an HP Recovery drive is listed in the window.

---

## Creating recovery discs

HP recommends that you create recovery discs to be sure that you can restore your system to its original factory state if you experience serious system failure or instability. Create these discs after setting up the computer for the first time.

Handle these discs carefully and keep them in a safe place. The software allows the creation of only one set of recovery discs.



If your computer does not include an integrated optical drive, you can use an optional external optical drive (purchased separately) to create recovery discs, or you can purchase recovery discs for your computer from the HP Web site.

---

Note the following guidelines before creating recovery discs:

- You will need high-quality DVD-R, DVD+R, BD-R (writable Blu-ray), or CD-R discs. All these discs are purchased separately. DVDs and BDs have a much higher capacity than CDs. If you use CDs, up to 20 discs may be required, whereas only a few DVDs or BDs are required.
  -  Read-write discs, such as CD-RW, DVD±RW, double-layer DVD±RW, and BD-RE (rewritable Blu-ray) discs, are not compatible with the Recovery Manager software.
- The computer must be connected to AC power during this process.
- Only one set of recovery discs can be created per computer.
- Number each disc before inserting it into the optical drive.
- If necessary, you can exit the program before you have finished creating the recovery discs. The next time you open Recovery Manager, you will be prompted to continue the disc creation process.

To create a set of recovery discs:

1. Select **Start > All Programs > Recovery Manager > Recovery Disc Creation**.
2. Follow the on-screen instructions.

## Backing up your information

As you add new software and data files, you should back up your system on a regular basis to maintain a reasonably current backup. Back up your system at the following times:

- At regularly scheduled times
  -  Set reminders to back up your information periodically.
- Before the computer is repaired or restored
- Before you add or modify hardware or software

Note the following when backing up:

- Create system restore points using the Windows System Restore feature, and periodically copy them to disc.
- Store personal files in the Documents library and back up this folder periodically.
- Back up templates stored in their associated programs.
- Save customized settings in a window, toolbar, or menu bar by taking a screen shot of your settings. The screen shot can be a time-saver if you have to reset your preferences.

To copy the screen and paste it into a word-processing document, follow these steps:

1. Display the screen.
2. Copy the screen:

To copy only the active window, press **alt+prt sc**.

To copy the entire screen, press **prt sc**.

3. Open a word-processing document, and then select **Edit > Paste**.
4. Save the document.

- You can back up your information to an optional external hard drive, a network drive, or discs.
- When backing up to discs, use any of the following types of discs (purchased separately): CD-R, CD-RW, DVD+R, DVD-R, or DVD±RW. The discs you use will depend on the type of optical drive installed in your computer.
  -  DVDs store more information than CDs, so using them for backup reduces the number of recovery discs required.
- When backing up to discs, number each disc before inserting it into the optical drive of the computer.

## Using Windows Backup and Restore

To create a backup using Windows Backup and Restore, follow these steps:



Be sure that the computer is connected to AC power before you start the backup process.



The backup process may take over an hour, depending on file size and the speed of the computer.

1. Select **Start > All Programs > Maintenance > Backup and Restore**.
2. Follow the on-screen instructions to set up and create a backup.



Windows includes the User Account Control feature to improve the security of your computer. You may be prompted for your permission or password for tasks such as installing software, running utilities, or changing Windows settings. Refer to Help and Support for more information.

## Using system restore points

When you back up your system, you are creating a system restore point. A system restore point allows you to save and name a snapshot of your hard drive at a specific point in time. You can then recover back to that point if you want to reverse subsequent changes made to your system.



Recovering to an earlier restore point does not affect data files saved or e-mails created since the last restore point.

You also can create additional restore points to provide increased protection for your system files and settings.

## When to create restore points

- Before you add or extensively modify software or hardware
- Periodically, whenever the system is performing optimally



If you revert to a restore point and then change your mind, you can reverse the restoration.



## Create a system restore point

1. Select **Start > Control Panel > System and Security > System**.
2. In the left pane, click **System Protection**.
3. Click the **System Protection** tab.
4. Under **Protection Settings**, select the disk for which you want to create a restore point.
5. Click **Create**.
6. Follow the on-screen instructions.

## Restore to a previous date and time

To revert to a restore point (created at a previous date and time), when the computer was functioning optimally, follow these steps:

1. Select **Start > Control Panel > System and Security > System**.
2. In the left pane, click **System protection**.
3. Click the **System Protection** tab.
4. Click **System Restore**.
5. Follow the on-screen instructions.

## Performing a recovery



---

You can recover only files that you have previously backed up. HP recommends that you use HP Recovery Manager to create a set of recovery discs (entire drive backup) as soon as you set up your computer.

---

Recovery Manager software allows you to repair or restore the system if you experience system failure or instability. Recovery Manager works from recovery discs or from a dedicated recovery partition (select models only) on the hard drive. However, if your computer includes a solid-state drive (SSD), you may not have a recovery partition. If that is the case, recovery discs have been included with your computer. Use these discs to recover your operating system and software.

---



Windows has its own built-in repair features, such as System Restore. If you have not already tried these features, try them before using Recovery Manager.

---



Recovery Manager recovers only software that was preinstalled at the factory. Software not provided with this computer must be downloaded from the manufacturer's Web site or reinstalled from the disc provided by the manufacturer.

---

## Recovering from the recovery discs

To restore the system from the recovery discs:

1. Back up all personal files.
2. Insert the first recovery disc into the optional external optical drive and restart the computer.
3. Follow the on-screen instructions.

## Recovering from the dedicated recovery partition (select models only)



---

Computers with an SSD may not have a recovery partition. If the computer does not have a recovery partition, you will not be able to recover using this procedure. Recovery discs have been included for computers that do not have a partition. Use these discs to recover your operating system and software.

---

On some models, you can perform a recovery from the partition on the hard drive, accessed by pressing either the **Start** button or **f11**. This restores the computer to its factory condition.

To restore the system from the partition, follow these steps:

1. Access Recovery Manager in either of the following ways:
  - ◆ Select **Start > All Programs > Recovery Manager > Recovery Manager**.
  - or –
  - ◆ Turn on or restart the computer, and then press **esc** while the “Press the ESC key for Startup Menu” message is displayed at the bottom of the screen. Then, press **f11** while the “Press <F11> for recovery” message is displayed on the screen.
2. Click **System Recovery** in the Recovery Manager window.
3. Follow the on-screen instructions.

## Connector pin assignments

### Audio-in (microphone)

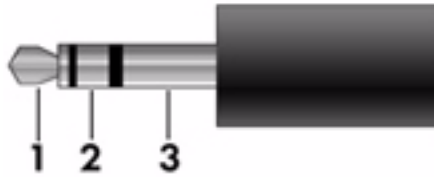

Pin	Signal
1	Audio signal in
2	Audio signal in
3	Ground

### Audio-out (headphone)

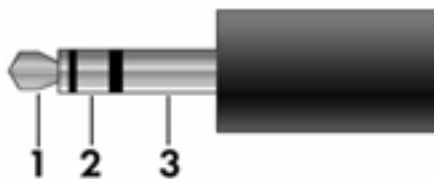

Pin	Signal
1	Audio out, left channel
2	Audio out, right channel
3	Ground

# HDMI

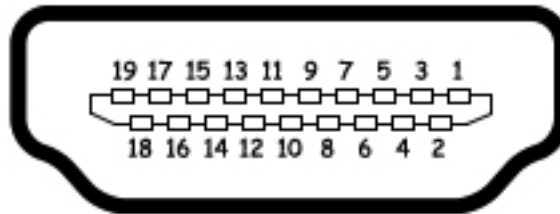

Pin	Signal
1	TMDS data 2+
2	TMDS data 2 shield
3	TMDS data 2-
4	TMDS data 1+
5	TMDS data 1 shield
6	TMDS data 1-
7	TMDS data 0+
8	TMDS data 0 shield
9	TMDS data 0-
10	TMDS clock+
11	TMDS clock shield
12	TMDS clock-
13	CEC
14	No connected
15	DDC clock
16	DDC data
17	Ground
18	+5V power
19	Hot plug detect

## RJ-45 (network)

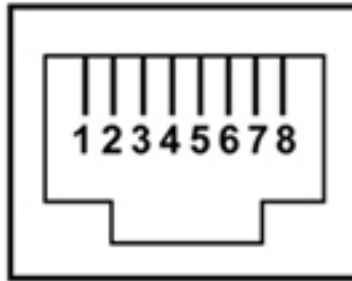

Pin	Signal
1	Transmit +
2	Transmit -
3	Receive +
4	Unused
5	Unused
6	Receive -
7	Unused
8	Unused

## Universal Serial Bus

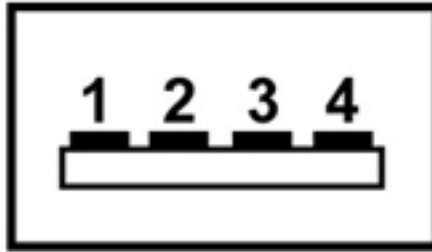

Pin	Signal
1	+5 VDC
2	Data
3	Data +
4	Ground

---

## Power cord set requirements

The wide-range input feature of the computer permits it to operate from any line voltage from 100 to 120 volts AC, or from 220 to 240 volts AC.

The 3-conductor power cord set included with the computer meets the requirements for use in the country or region where the equipment is purchased.

Power cord sets for use in other countries and regions must meet the requirements of the country or region where the computer is used.

### Requirements for all countries and regions

The following requirements are applicable to all countries and regions:

- The length of the power cord set must be at least 1.5 m (5.0 ft) and no more than 2.0 m (6.5 ft).
- All power cord sets must be approved by an acceptable accredited agency responsible for evaluation in the country or region where the power cord set will be used.
- The power cord sets must have a minimum current capacity of 10 amps and a nominal voltage rating of 125 or 250 V AC, as required by the power system of each country or region.
- The appliance coupler must meet the mechanical configuration of an EN 60 320/IEC 320 Standard Sheet C13 connector for mating with the appliance inlet on the back of the computer.

## Requirements for specific countries and regions

Country/region	Accredited agency	Applicable note number
Australia	EANSW	1
Austria	OVE	1
Belgium	CEBC	1
Canada	CSA	2
Denmark	DEMKO	1
Finland	FIMKO	1
France	UTE	1
Germany	VDE	1
Italy	IMQ	1
Japan	METI	3
The Netherlands	KEMA	1
Norway	NEMKO	1
The People's Republic of China	CCC	5
South Korea	EK	4
Sweden	SEMKO	1
Switzerland	SEV	1
Taiwan	BSMI	4
The United Kingdom	BSI	1
The United States	UL	2

1. The flexible cord must be Type HO5VV-F, 3-conductor, 1.0-mm<sup>2</sup> conductor size. Power cord set fittings (appliance coupler and wall plug) must bear the certification mark of the agency responsible for evaluation in the country or region where it will be used.
2. The flexible cord must be Type SPT-3 or equivalent, No. 18 AWG, 3-conductor. The wall plug must be a two-pole grounding type with a NEMA 5-15P (15 A, 125 V) or NEMA 6-15P (15 A, 250 V) configuration.
3. The appliance coupler, flexible cord, and wall plug must bear a "T" mark and registration number in accordance with the Japanese Dentori Law. The flexible cord must be Type VCT or VCTF, 3-conductor, 1.00-mm<sup>2</sup> conductor size. The wall plug must be a two-pole grounding type with a Japanese Industrial Standard C8303 (7 A, 125 V) configuration.
4. The flexible cord must be Type RVV, 3-conductor, 0.75-mm<sup>2</sup> conductor size. Power cord set fittings (appliance coupler and wall plug) must bear the certification mark of the agency responsible for evaluation in the country or region where it will be used.
5. The flexible cord must be Type VCTF, 3-conductor, 0.75-mm<sup>2</sup> conductor size. Power cord set fittings (appliance coupler and wall plug) must bear the certification mark of the agency responsible for evaluation in the country or region where it will be used.





## Battery

When a battery has reached the end of its useful life, do not dispose of it in general household waste. Follow the local laws and regulations in your area for computer battery disposal.

## Display

 **WARNING:** The backlight contains mercury. Exercise caution when removing and handling the backlight, to avoid damaging this component and causing exposure to the mercury.

 **CAUTION:** The procedures in this chapter can result in damage to display components. The only components intended for recycling purposes are the liquid crystal display (LCD) panel and the backlight. When you remove these components, handle them carefully.

 **Materials Disposal.** The backlight in the display assembly of this HP product contains mercury, which might require special handling at end-of-life. Disposal of mercury may be regulated because of environmental considerations. For disposal or recycling information, contact your local authorities, or see the Electronic Industries Alliance (EIA) Web site at <http://www.eiae.org>.

This section provides disassembly instructions for the display assembly. The display assembly must be disassembled to gain access to the backlight ❶ and the liquid crystal display (LCD) panel ❷.



 The procedures provided in this chapter are general disassembly instructions. Specific details, such as screw sizes, quantities, and locations, and component shapes and sizes, can vary from one computer model to another.

To disassemble the display assembly, follow these steps:

1. Remove all screw covers ❶ and screws ❷ that secure the display bezel to the display assembly.

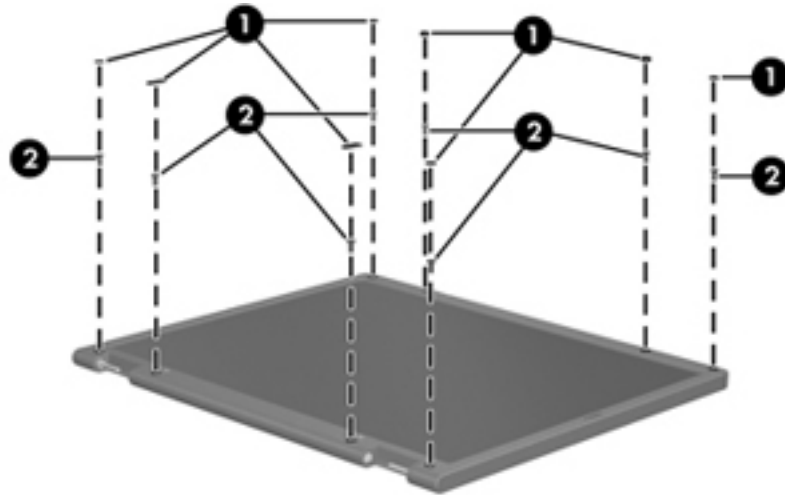

2. Lift up and out on the left and right inside edges ❶ and the top and bottom inside edges ❷ of the display bezel until the bezel disengages from the display assembly.
3. Remove the display bezel ❸.

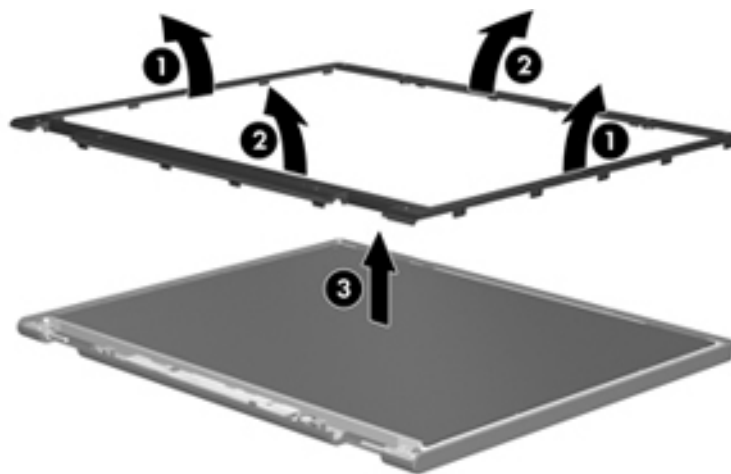

4. Disconnect all display panel cables ❶ from the display inverter, and then remove the inverter ❷.

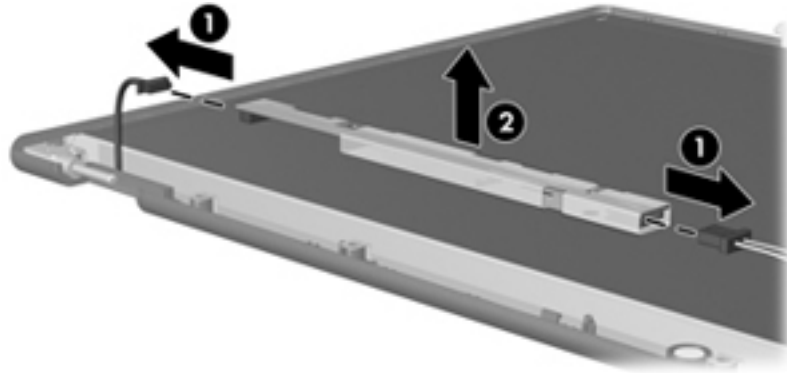

5. Remove all screws ❶ that secure the display panel assembly to the display enclosure.

6. Remove the display panel assembly ❷ from the display enclosure.

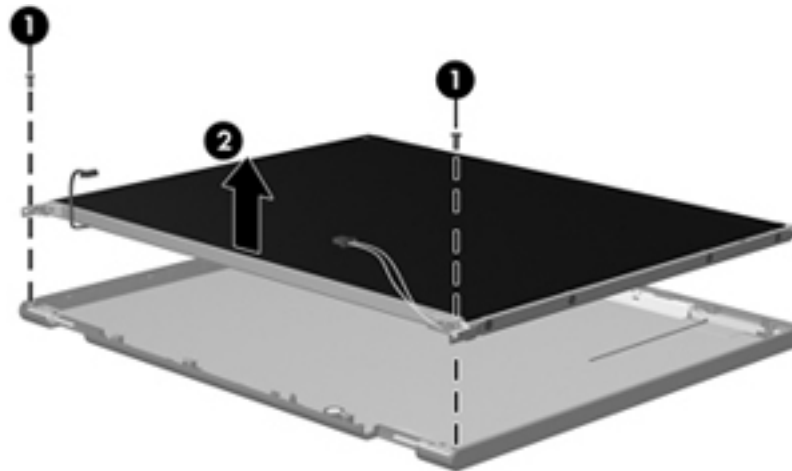

7. Turn the display panel assembly upside down.

8. Remove all screws that secure the display panel frame to the display panel.

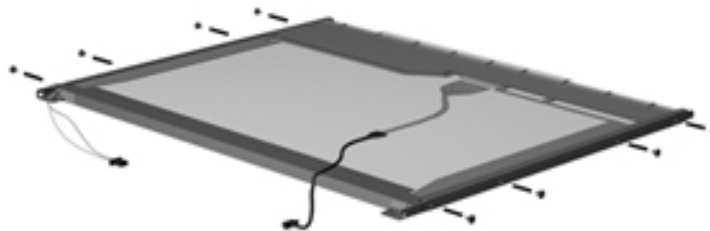

9. Use a sharp-edged tool to cut the tape ❶ that secures the sides of the display panel to the display panel frame.
10. Remove the display panel frame ❷ from the display panel.

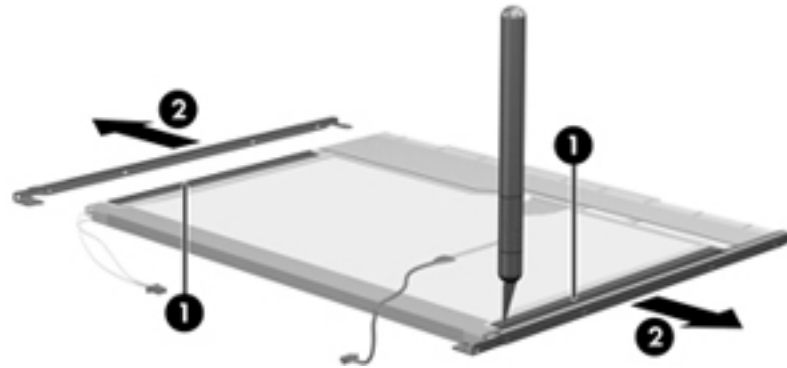

11. Remove the screws ❶ that secure the backlight cover to the display panel.
12. Lift the top edge of the backlight cover ❷ and swing it outward.

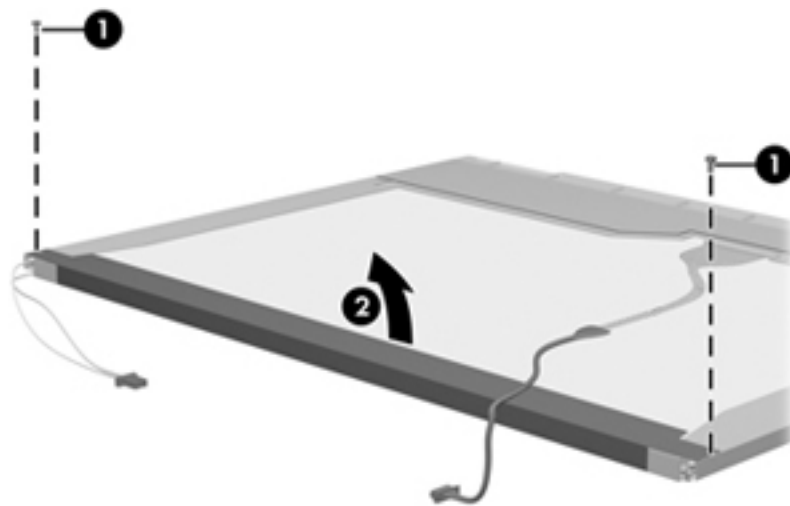

13. Remove the backlight cover.
14. Turn the display panel right-side up.
15. Remove the backlight cables ❶ from the clip ❷ in the display panel.

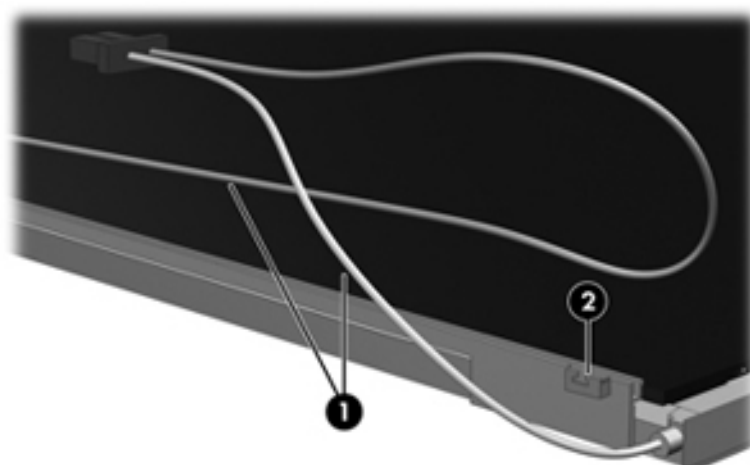

16. Turn the display panel upside down.
17. Remove the backlight frame from the display panel.



**WARNING:** The backlight contains mercury. Exercise caution when removing and handling the backlight, to avoid damaging this component and causing exposure to the mercury.

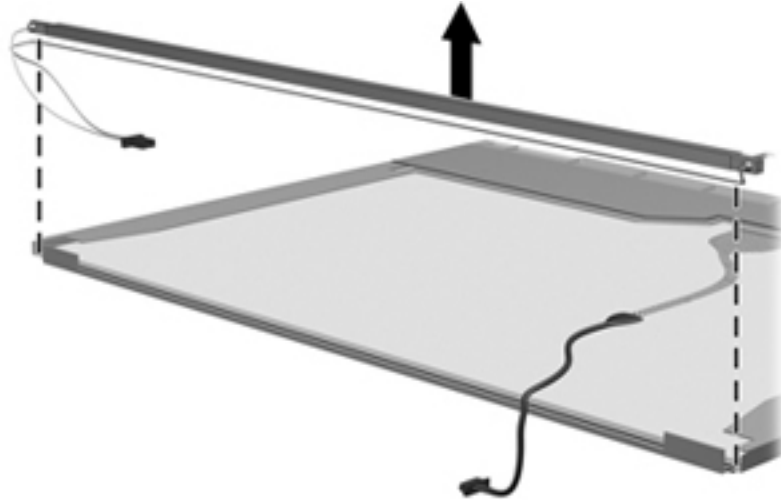

18. Remove the backlight from the backlight frame.

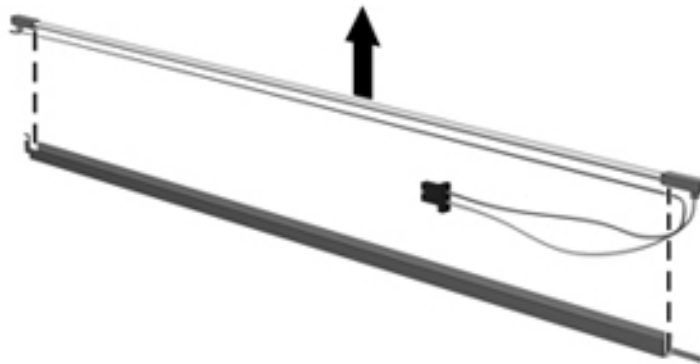

19. Disconnect the display cable ❶ from the LCD panel.
20. Remove the screws ❷ that secure the LCD panel to the display rear panel.
21. Release the LCD panel ❸ from the display rear panel.
22. Release the tape ❹ that secures the LCD panel to the display rear panel.

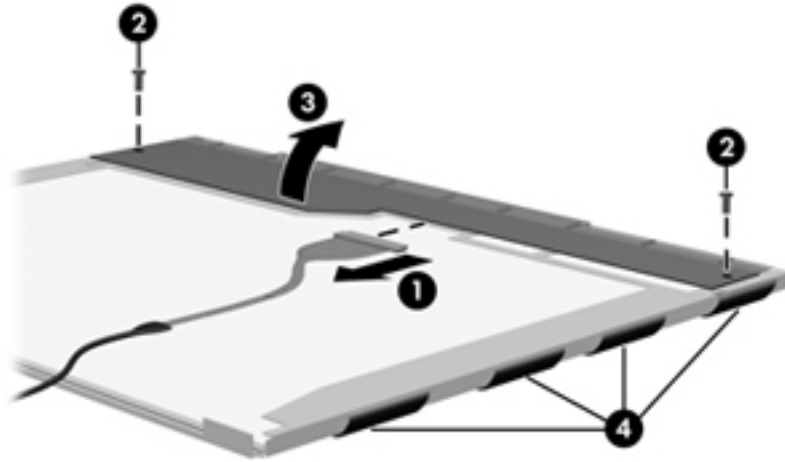

23. Remove the LCD panel.

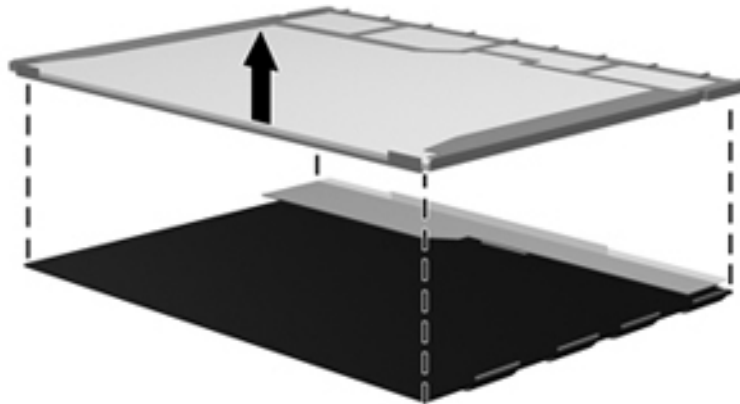

24. Recycle the LCD panel and backlight.

## A

- AC adapter, spare part numbers 3-13, 3-14
- accessory battery connector 2-10
- Action Key Mode 5-4
- action keys 2-4
- Administrator password 5-3
- ambient light sensor 2-2
- ambient light sensor module
  - removal 4-35
  - spare part number 3-10, 3-16, 4-35, 4-39
- ambient light sensor module cable
  - removal 4-39
  - spare part number 3-10
- antennas
  - disconnecting 4-18
  - locations 2-2
  - removal 4-40
  - spare part number 3-10, 3-16, 4-40
- audio, product description 1-2
- audio-in jack
  - connector pinout 9-1
  - location 2-9
- audio-out jack
  - connector pinout 9-1
  - location 2-9

## B

- base enclosure, spare part numbers 3-8, 3-17
- battery
  - removal 4-7
  - spare part numbers 3-8, 3-16, 3-18, 4-7
- battery bay 2-10
- battery light 2-8
- battery lock 2-10
- battery release latch 2-10
- BIOS
  - determining the version 5-5
  - downloading an update 5-6
  - updating 5-5
- Bluetooth module
  - removal 4-35
  - spare part number 3-10, 3-14, 4-35
- Bluetooth module cable
  - removal 4-39
  - spare part number 3-10, 3-17, 4-39

- Blu-ray ROM DVD±R/RW SuperMulti Double-Layer Drive
  - precautions 4-2
  - spare part number 3-12, 3-16, 3-17
  - specifications 6-5
- Boot Options 5-4
- bottom components 2-10
- button components 2-3
- buttons
  - power 2-3
  - TouchPad 2-7
  - TouchPad on/off 2-7

## C

- cables, service considerations 4-1
- calculator** key 2-4
- caps lock light 2-5
- chipset, product description 1-1
- components
  - bottom 2-10
  - button 2-3
  - display 2-2
  - front 2-8
  - keys 2-4
  - left-side 2-8
  - lights 2-5
  - right-side 2-9
  - top 2-2
  - TouchPad 2-6
  - TouchPad buttons 2-7
- computer feet
  - locations 4-6
  - spare part number 4-6
- computer specifications 6-1
- connector pinout
  - audio-in jack 9-1
  - audio-out jack 9-1
  - HDMI port 9-2
  - headphone jack 9-1
  - microphone jack 9-1
  - network jack 9-3
  - RJ-45 jack 9-3
  - USB port 9-4
- connectors, service considerations 4-1

**D**

- Diagnostics menu 5–4
- Digital Media Slot, location 2–8
- display assembly
  - removal 4–33
  - spare part numbers 3–4, 3–15, 3–17, 3–18, 4–33
- display bezel
  - removal 4–34
  - spare part number 3–10, 3–15, 4–34
- display components
  - illustrated 2–2
  - recycling 11–1
- display enclosure, spare part numbers 3–10, 3–15, 3–17
- Display Hinge Kit, spare part number 3–10, 3–15
- display hinges
  - removal 4–36
  - spare part number 3–10, 3–15, 4–36
- display inverter, removal 11–3
- display panel
  - product description 1–1
  - removal 4–37
  - spare part numbers 3–10, 3–15, 3–18, 4–37
- display panel cable
  - removal 4–38
  - spare part number 3–10, 3–16, 4–38
- Display Screw Kit, spare part number 3–10, 3–15
- display switch 2–2
- drive light 2–8
- DVD±RW and CD-RW SuperMulti Double-Layer Combo Drive
  - precautions 4–2
  - spare part number 3–12, 3–16, 3–17
  - specifications 6–6

**E**

- electrostatic discharge 4–2
- equipment guidelines 4–4
- eSATA/USB port, location 2–9
- esc** key 2–4
- Ethernet, product description 1–2
- external media card, product description 1–3

**F**

- Fan Always On 5–4
- fan/heat sink assembly
  - removal 4–22, 4–27
  - spare part numbers 3–7, 3–16, 3–17, 4–22, 4–27
- Fast Charge Mode 5–4
- feet
  - locations 4–6
  - spare part number 4–6
- fn** key 2–4
- front components 2–8

**G**

- graphics, product description 1–1
- grounding equipment and methods 4–2

**H**

- hard drive
  - precautions 4–2
  - product description 1–2
  - removal 4–20
  - spare part numbers 3–7, 3–12, 3–16, 3–17, 3–18, 4–20
  - specifications 6–3
- hard drive cable, spare part numbers 3–7, 3–12, 3–16
- Hard Drive Hardware Kit, spare part numbers 3–7, 3–12, 3–16
- HDMI port
  - connector pinout 9–2
  - location 2–9
- HDMI-to-VGA adapter, spare part number 3–13, 3–14
- headphone jack
  - connector pinout 9–1
  - location 2–9
- HP Notebook protective case, spare part numbers 3–13, 3–17

**J**

- jacks
  - audio-in 2–9
  - audio-out 2–9
  - headphone 2–9
  - microphone 2–9
  - network 2–9
  - RJ-45 2–9

**K**

- key components 2–4
- keyboard
  - product description 1–4
  - removal 4–12
  - spare part numbers 3–4, 3–5, 3–16, 3–17, 4–12
- Keyboard Hardware Kit, spare part number 3–5, 3–16, 4–12
- keys
  - action 2–4
  - calculator** 2–4
  - esc** 2–4
  - fn** 2–4
  - mail** 2–4
  - Media Launch** 2–4
  - print options** 2–4
  - Web** 2–4
  - Windows applications 2–4
  - Windows logo 2–4
  - wireless** 2–4



**L**

- Language Support 5–4
- left-side components 2–8
- light components 2–5
- lights
  - battery 2–8
  - caps lock 2–5
  - drive 2–8
  - mute 2–5
  - power 2–5
  - TouchPad 2–5
  - webcam 2–2
  - webcam infrared 2–2
  - wireless 2–5

**M**

- mail** key 2–4
- Main menu 5–3
- mass storage device
  - illustrated 3–11
  - product description 1–2
  - removal 4–20
  - spare part numbers 3–11, 4–20
- Media Launch** key 2–4
- memory module
  - removal 4–8, 4–15
  - spare part numbers 3–5, 3–16, 4–8, 4–15
- memory module compartment 2–10
- memory module compartment cover
  - removal 4–8
  - spare part number 3–8, 3–17
- Memory Test 5–4
- memory, product description 1–1
- microphone
  - locations 2–2
  - product description 1–2
- microphone jack
  - connector pinout 9–1
  - location 2–9
- model description 3–2, 4–5
- mute light 2–5

**N**

- network jack
  - connector pinout 9–3
  - location 2–9

**O**

- operating system, product description 1–4
- optical drive
  - precautions 4–2
  - product description 1–2

- spare part numbers 3–12, 3–16, 3–17
- specifications 6–5, 6–6

**P**

- packing guidelines 4–3
- part number description 3–2, 4–5
- plastic parts 4–1
- Plastics Kit, spare part number 3–8, 3–17
- pointing device, product description 1–4
- ports
  - eSATA/USB 2–9
  - HDMI 2–9
  - product description 1–4
  - Universal Serial Bus (USB) 2–9
- power button 2–3
- power button board and cable
  - removal 4–25
  - spare part number 3–7, 3–17, 4–25
- power connector 2–8
- power connector cable
  - removal 4–26
  - spare part number 3–7, 3–17, 4–26
- power cord
  - set requirements 10–1
  - spare part numbers 3–13, 3–14
- power light 2–5
- power requirements, product description 1–3
- Power-On Password 5–3
- Primary Hard Disk Self Test 5–4
- print options** key 2–4
- processor
  - product description 1–1
  - removal 4–24
  - spare part numbers 3–7, 3–17, 3–18, 4–24
- processor fan/heat sink assembly
  - removal 4–22
  - spare part number 3–7, 3–16, 4–22
- product description
  - audio 1–2
  - chipset 1–1
  - display panel 1–1
  - Ethernet 1–2
  - external media card 1–3
  - graphics 1–1
  - keyboard 1–4
  - memory 1–1
  - microphone 1–2
  - operating system 1–4
  - optical drive 1–2
  - pointing device 1–4
  - ports 1–4
  - power requirements 1–3
  - processor 1–1

- security 1–4
- serviceability 1–4
- wireless 1–3
- product name 1–1, 3–2, 4–5
- product number description 3–2, 4–5

**R**

- recovery, system 8–1
- recycling
  - battery 11–1
  - display components 11–1
- removal/replacement
  - preliminaries 4–1
  - procedures 4–6
- right-side components 2–9
- RJ-45 jack
  - connector pinout 9–3
  - location 2–9
- RTC battery
  - removal 4–19
  - spare part number 3–5, 3–17, 4–19
- Rubber Feet Kit, spare part number 3–8, 3–14, 4–6

**S**

- Screw Kit, spare part number 3–13, 3–17
- screw listing 7–1
- Secondary Hard Disk Self Test 5–4
- security cable slot 2–9
- Security menu 5–3
- security, product description 1–4
- serial number 3–2, 4–5
- service considerations 4–1
- service tag 3–1, 4–5
- serviceability, product description 1–4
- Setup Utility
  - changing the language 5–1
  - Diagnostics menu 5–4
  - displaying system information 5–2
  - exiting 5–3
  - Main menu 5–3
  - menus 5–3
  - navigating 5–2
  - restoring default settings 5–2
  - Security menu 5–3
  - selecting 5–2
  - starting 5–1
  - System Configuration menu 5–4
  - using 5–1

- speaker assembly
  - removal 4–14
  - spare part number 3–7, 3–17, 4–14
- speaker, location 2–8, 2–9
- specifications
  - Blu-ray ROM DVD±R/RW SuperMulti
    - Double-Layer Drive 6–5
  - computer 6–1
  - display assembly 6–2
  - DVD±RW and CD-RW SuperMulti Double-Layer
    - Combo Drive 6–6
  - hard drive 6–3
  - optical drive 6–5, 6–6
  - system DMA 6–7
  - system I/O address 6–9
  - system interrupt 6–8
  - system memory map 6–7
- system board
  - removal 4–29
  - spare part number 3–8, 3–15, 4–29
- System Configuration menu 5–4
- system DMA specifications 6–7
- system I/O address specifications 6–9
- System Information 5–3
- system interrupt specifications 6–8
- system memory map specifications 6–7
- system recovery 8–1

**T**

- tools required 4–1
- top components 2–2
- top cover
  - removal 4–10
  - spare part numbers 3–4, 3–17, 4–10
- TouchPad 2–6
- TouchPad button 2–7
- TouchPad light 2–5
- TouchPad on/off button 2–7

**U**

- Universal Serial Bus (USB) port
  - connector pinout 9–4
  - location 2–9

**V**

- vent 2–8, 2–9, 2–10
- video fan/heat sink assembly
  - removal 4–27
  - spare part number 3–7, 3–17, 4–27
- Virtualization Technology 5–4

**W**

warranty period 3-2, 4-5

**Web** key 2-4

webcam 2-2

webcam infrared light 2-2

webcam light 2-2

webcam/microphone module

removal 4-36

spare part number 3-10, 3-16, 4-36

Windows applications key 2-4

Windows logo key 2-4

wireless antennas

disconnecting 4-18

locations 2-2

removal 4-40

spare part number 3-10, 3-16, 4-40

**wireless** key 2-4

wireless light 2-5

wireless, product description 1-3

WLAN module

removal 4-16

spare part numbers 3-5, 3-6, 3-7, 3-14, 3-15,  
3-18, 4-16

workstation guidelines 4-4